

EATON | **Vickers**

Hydrokraft Piston Motors

Technical Catalog

MVX

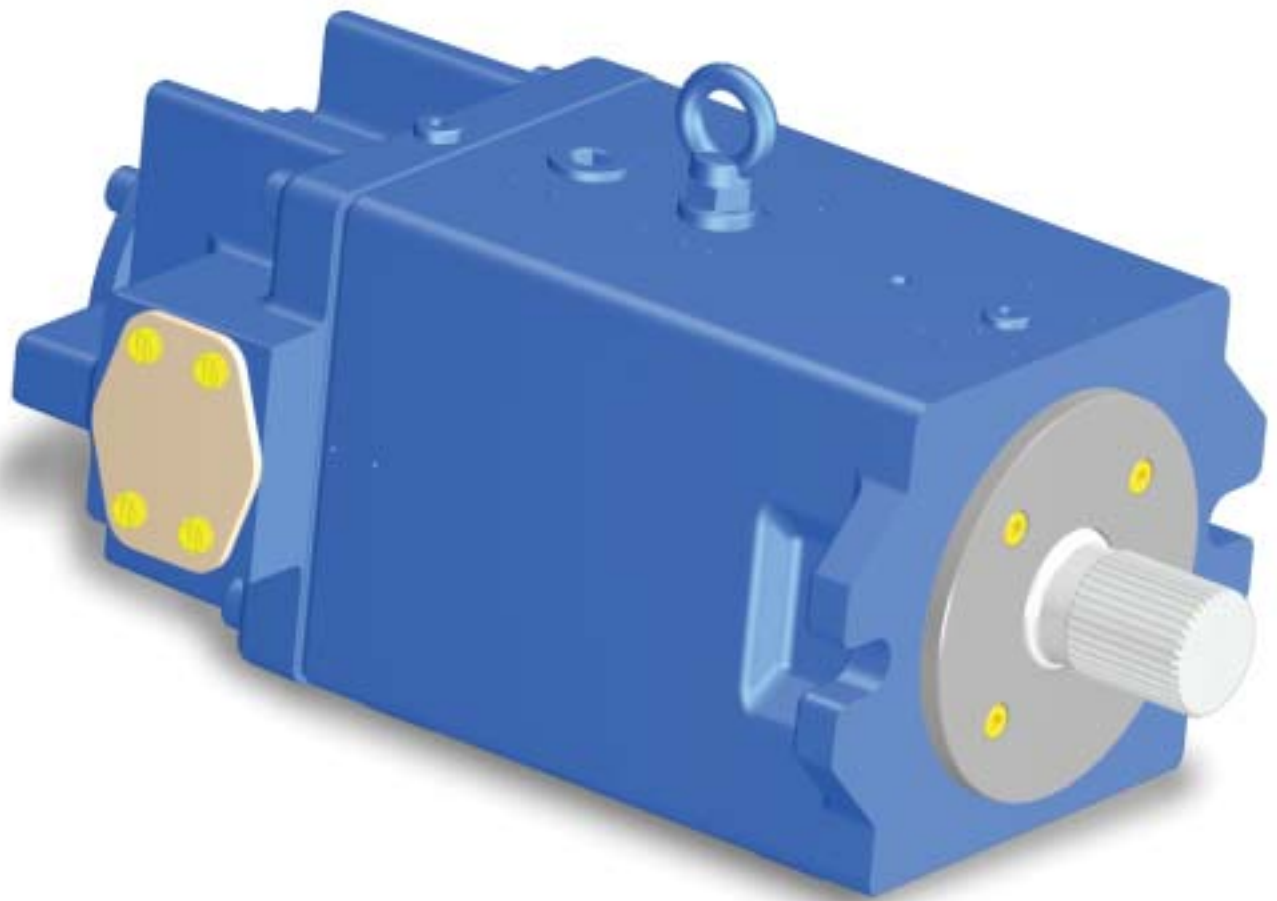

VICKERS[®]

Table of Contents

Introduction	3
Model Code	
Form Page	4
Basic Motors	5
No Control	6
ES Control	7
HG Control	8
FE Control	9
DP Control	10
SP Control	11
Special Features	12
Motor Specifications	
US	13
Metric	14
Controls	
Electric Motor Displacement Control, ES	15
Manual Adjustment Displacement Control, FE, HG	16
Pressure Signal Adjustment Displacement Control, DP	17
Electrohydraulic Servo Adjustment, SP	18
Pump Dimensions*	
MFXS-066 - 180**	20
MVXS-066 - 180 ES Control**	22
MVXS-066 - 180 HG Control**	24
MVXS-066 - 180 FE Control**	26
MVXS-066 - 180 DP Control**	28
MVXS-066 - 180 SP Control**	30
Installation Data	32
Application Data	
Fluid Recommendations	33

* Dimensions - MFXS -250 / MVXS-250 ask for special drawings.

Used only for replacement.

For new applications please use MFWS / MVWS.

** MFXS / MVXS -130/180, for new applications please use MFWS / MVWS-130/180.

Introduction

- Axial piston motors with swashplate design and can be applied to hydrostatic drives.
- Pressure up to 350 bar. Rated speed up to 1800 min⁻¹.
- A range of control options allow matching of motors to any application.
- Rotating and pressure loaded parts are pressure balanced.
- High efficiency from automatic pressure balancing of cylinder block to valve plate.
- Oversized shaft bearings for long life and thru-drive capability.
- Highly resistant to dirt because of automatic wear compensation.
- Low sound level assured by swashplate design and other proven features.

AVAILABLE DISPLACEMENT SIZES

066 ccm
090 ccm
130 ccm
180 ccm

Displacement controls:

ES - Electric motor displacement control

HG - Handwheel displacement control (Special feature)

FE - Screw adjustment control (Special feature)

DP - Pressure signal displacement control

SP - Electro hydraulic displacement control

Typical section of MFX motor

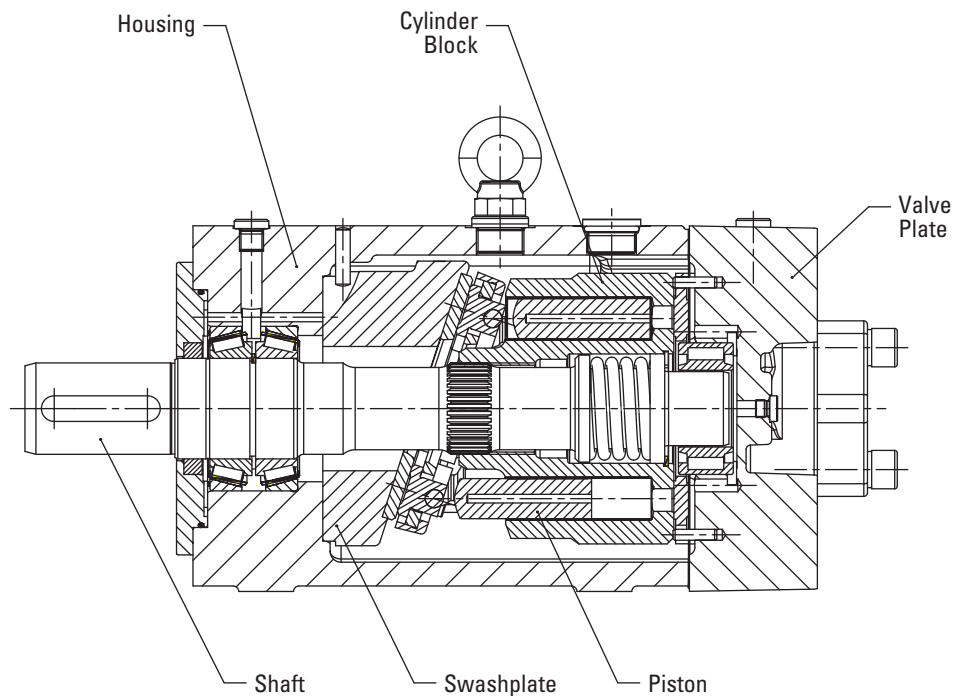

Dimensional information listed in this catalog is subject to change without notice.

Model Code

Motors

"X" Series - Basic Motor

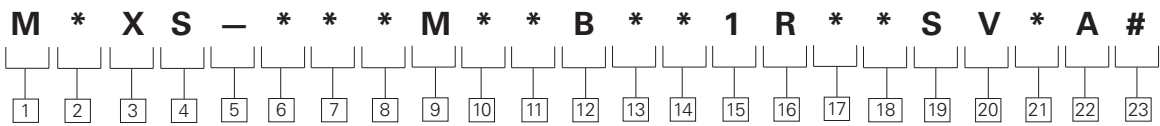

1 Motor

M – Motor

2 Displacement

F – Fixed Displacement
V – Variable Displacement

3 Pump Series

X – "X" Series
(was 20 design)

4 Configuration

S – Single Unit

5 Separator

– Separator

6 7 8 Displacement Size

066 – 66 cm³/r [4.0 in³/rev]
090 – 90 cm³/r [5.5 in³/rev]
130 – 130 cm³/r [7.9 in³/rev]
180 – 180 cm³/r [11.0 in³/rev]
250 – 250 cm³/r [15.3 in³/rev]
(for Spares only)
??? – Non-Standard Displacement (MFX Only)

9 Basic Standard

M – Metric

10 11 Mounting Flange

02 – ISO 3019/2-125A2HW
04 – ISO 3019/2-160A2HW
06 – ISO 3019/2-200A2HW
See Chart Below

12 Rotation Direction

B – Both

13 Adjustment Stops

0 – No Stop
4 – Mechanical Adjustment Stop Side A (MVX only)
5 – Mechanical Adjustment Stop Side B (MVX only)
6 – Mechanical Adjustment Stops Side A and B (MVX only)

NOTE:
4 is used as max. Adjustment on Side A.
5 is used as min. Adjustment stop side A. When **0** is specified, min. Adjustment Stop is set at 35 % of Vgmax
6 is the combination of **4** and **5** together

14 Thru-Drive Options

0 – None
K – Tachogenerator
E – Speed Limit Switch (Two Switches)

15 Main Ports

1 – SAE Ports - Metric Bolts

16 Main Port Orientation

R – Radial (Side Ports)

17 18 Main Drive Shaft End

01 – ISO Straight Key
02 – ISO Spline

19 Drive Shaft Seal Configuration

S – Single Shaft Seal

20 Seal Material

V – Viton*
*Viton is a trademark of E.I. DuPont (other materials available, contact your Eaton Representative)

21 Yoke Position Indicator

0 – No Position Indicator
V – Visual Position Indicator
P – Position Sensor
M – Sensor with Visual Indicator

22 Surface Finish

A – Blue Painted
Other options on special request available. Contact Eaton Sales.

23 Add Control Model Code

Code – Code (characters 23...37) on the following pages

MOUNTING FLANGE OPTIONS AVAILABLE	066	090	130	180	250
ISO 3019/2-125A2HW	18	19			
ISO 3019/2-160A2HW			20	21	
ISO 3019/2-200A2HW					22

Model Code

Motors

"X" Series - No Control

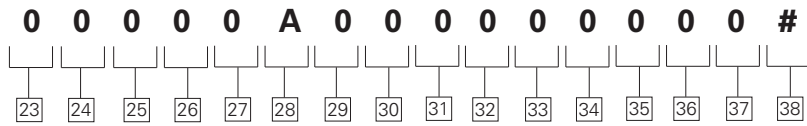

23 24 Control Type

00 – No Control
(for MFW only)

25 Displacement Adjustment Options

0 – Not Applicable

26 27 Electronic Controls

00 – Not Required

28 Yoke Displacement Zone

A – Single Side of Center "A"

29 Extra Functions

0 – Not Required

30 Pressure Control Options

0 – Not Applicable

31 Position Monitoring

0 – No Position Monitoring

32 Electric Motor Type

0 – No Electric Motor

33 Control Voltage

0 – Not Applicable

34 35 36 37 Customer Adjustment Specification

0000 – None

38 Special Features

Add special feature description (characters 44...46) on page 12 if required.

Model Code

Motors

"X" Series - ES Control

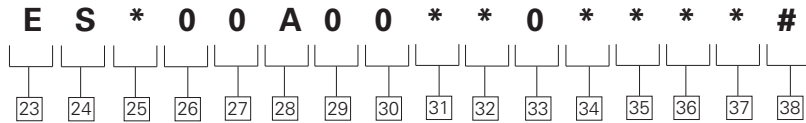

23 24 Control Type

ES – Electric Motor Displacement Control

25 Displacement Adjustment Options

- M** – Electric Motor - (Fast Response)
- N** – Electric Motor - (Medium Response)
- P** – Electric Motor - (Slow Response)

26 27 Electronic Controls

00 – Not Required

28 Yoke Displacement Zone

A – Single Side of Center "A"

29 Extra Functions

0 – Not Required

30 Pressure Control Options

0 – Not Applicable

31 Position Monitoring

- A** – 4 Limit Switches
- B** – 8 Limit Switches
- P** – 4 Limit Switches + Sensor
- T** – 8 Limit Switches + Sensor

32 Electric Motor Type

- 2** – Motor with Brake (IP-54)
- 3** – Motor without Brake (Explosion Proof)

33 Control Voltage

0 – Not Applicable

34 35 36 37 Customer Adjustment Specification

0000 – None
???? – Yes (final number will be assigned by Eaton. Specify on table below)

38 Special Features

Add special feature description (characters 38...42) on page 12 if required.

CUSTOMER ADJUSTMENT SPECIFICATIONS

		Unit	Standard Adjustment	Customer Specified Adjustment	Remarks
All Revolution Adjustments Set at		rpm	1500	—	
Mech. Stop Side A (Used as Max. Adjustment Stop Side A)		cm ³ /rev	Vg _{max}		
Mech. Stop Side B (Used as Max. Adjustment Stop Side A)		cm ³ /rev	35 5/8 Vg _{max}		< 35% not possible
Displacement Adjusted to		cm ³ /rev	60% Vg _{max}		
Position Monitoring Switch	1	cm ³ /rev	35% Vg _{max}		< 35% not possible
	2	cm ³ /rev	95% Vg _{max}		> 95% not possible
	3	cm ³ /rev	—		
	4	cm ³ /rev	—		
	5	cm ³ /rev	—		
	6	cm ³ /rev	—		
	7	cm ³ /rev	—		
	8	cm ³ /rev	—		

Model Code

Motors

"X" Series - HG Control

H	G	0	0	0	A	0	0	0	0	0	*	*	*	*	#
□	□	□	□	□	□	□	□	□	□	□	□	□	□	□	□
23	24	25	26	27	28	29	30	31	32	33	34	35	36	37	38

23 24 Control Type

HG – Handwheel Displacement Control

25 Displacement Adjustment Options

0 – Not Applicable

26 27 Electronic Controls

00 – Not Required

28 Yoke Displacement Zone

A – Single Side of Center "A"

29 Extra Functions

0 – Not Required

30 Pressure Control Options

0 – Not Applicable

31 Position Monitoring

0 – No Position Monitoring

32 Electric Motor Type

0 – No Electric Motor

33 Control Voltage

0 – Not Applicable

34 35 36 37 Customer Adjustment Specification

0000 – None

???? – Yes (final number will be assigned by Eaton. Specify on table below)

38 Special Features

Add special feature description (characters 38..42) on page 12 if required.

CUSTOMER ADJUSTMENT SPECIFICATIONS

	Unit	Standard Adjustment	Customer Specified Adjustment	Remarks
All Revolution Adjustments Set at	rpm	1500	—	
Displacement Adjusted to	cm ³ /rev	V _{gmax}		

Model Code

Motors

"X" Series - FE Control

F	E	0	0	0	A	0	0	0	0	0	*	*	*	*	#
□	□	□	□	□	□	□	□	□	□	□	□	□	□	□	□
23	24	25	26	27	28	29	30	31	32	33	34	35	36	37	38

23 24 Screw Adjustment Displacement Control

FE – Screw Adjustment Displacement Control

25 displacement Adjustment Options

0 – Not Applicable

26 27 Electronic Controls

00 – Not Required

28 Yoke Displacement Zone

A – Single Side of Center "A"

29 Extra Functions

0 – Not Required

30 Pressure Control Options

0 – Not Applicable

31 Position Monitoring

0 – No Position Monitoring

32 Electric Motor Type

0 – No Electric Motor

33 Control Voltage

0 – Not Applicable

34 35 36 37 Customer Adjustment Specification

0000 – None

???? – Yes (final number will be assigned by Eaton. Specify on table below)

38 Special Features

Add special feature description (characters 38..42) on page 12 if required.

CUSTOMER ADJUSTMENT SPECIFICATIONS

	Unit	Standard Adjustment	Customer Specified Adjustment	Remarks
All Revolution Adjustments Set at	rpm	1500	—	
Displacement Adjusted to	cm ³ /rev	Vg _{max}		

Model Code

Motors

"X" Series - DP Control

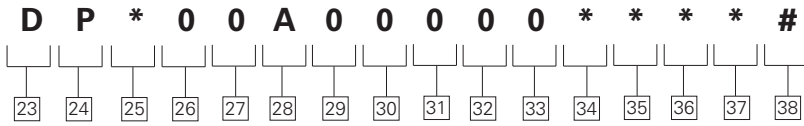

23 24 Control Type

DP – Pressure Signal Adjustment
Displacement Control

25 Displacement

Adjustment Options

G – Mounting Interface
Cetop 3 Only
H – Remote Port G 1/4
J – Proportional Relief inc.
Electronics

26 27 Electronic Controls

00 – Not Required

28 Yoke Displacement Zone

A – Single Side of Center "A"

29 Extra Functions

0 – Not Required

30 Pressure Control Options

0 – Not Applicable

31 Position Monitoring

0 – No Position Monitoring

32 Electric Motor Type

0 – No Electric Motor

33 Control Voltage

0 – Not Applicable

34 35 36 37 Customer Adjustment Specification

0000 – None
???? – Yes (final number will be assigned by Eaton. Specify on table below)

38 Special Features

Add special feature description (characters 38...42) on page 12 if required.

CUSTOMER ADJUSTMENT SPECIFICATIONS

	Unit	Standard Adjustment	Customer Specified Adjustment	Remarks
All Revolution Adjustments below set at ..	rpm	1500	—	
Pilot Pressure for Size 250 & 360 (External)	bar	60	—	
Pilot Pressure for Size 500 & 750 (External)	bar	80	—	
Mech. Stop Side A (used as max Adjustment Stop Side A)	cm ³ /rev.	Vg _{max}		
Mech. Stop Side B (used as min Adjustment Stop Side A)	cm ³ /rev.	35% of Vg _{max}		<35% not possible

Model Code

Motors

"X" Series - SP Control

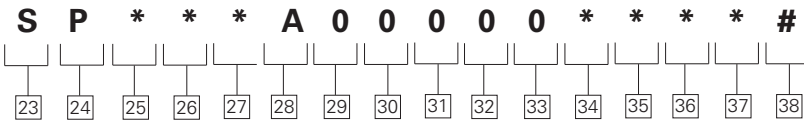

23 24 Control Type

SP – Proportional Valve Displacement Control

25 Displacement Adjustment Options

C – With CETOP 3 Prop Valve KDG4V 3
F – With CETOP 5 Prop Valve

26 27 Electronic Controls

03 – ER 9.3 - 10 (CETOP 3)
 04 – ER 9.4 - 10 (CETOP 5)

28 Yoke Displacement Zone

A – Single Side of Center "A"

29 Extra Functions

0 – Not Required

30 Pressure Control Options

0 – Not Applicable

31 Position Monitoring

0 – No Position Monitoring

32 Elec Motor Type

0 – No Electric Motor

33 Control Voltage

0 – Not Applicable

34 35 36 37 Customer Adjustment Specification

0000 – None
???? – Yes (final number will be assigned by Eaton. Specify on table below)

38 Special Features

Add special feature description (characters 38..40) on page 12 if required.

***CUSTOMER ADJUSTMENT SPECIFICATIONS**

	Unit	Standard Adjustment	Customer Specified Adjustment	Remarks
All Revolution Adjustments below set at ..	rpm	1500	—	
Pilot Pressure	bar	60	—	
Mech. Stop Side A (used as max Adjustment Stop Side A)	cm ³ /rev.	Vg _{max}		
Mech. Stop Side B (used as min Adjustment Stop Side B)	cm ³ /rev.	35% of Vg _{max}		
Max. Stop by Control Side A	cm ³ /rev.	95% of Vg _{max}	EI Card Adjustment done by customer	Refer to EI card Manual
Min. Stop by Control Side A	cm ³ /rev.	35% of Vg _{max} +/-2.5%	EI Card Adjustment done by customer	Refer to EI card Manual
Ramp Time 0 → A For 100% Stroke	sec	0	EI Card Adjustment done by customer	Refer to EI card Manual
Ramp Time A → 0 For 100% Stroke	sec	0	EI Card Adjustment done by customer	Refer to EI card Manual
Preset Input Signals S1....S4	L/min	—	EI Card Adjustment done by customer	Refer to EI card Manual

Model Code

Motors

"X" Series - Special Features

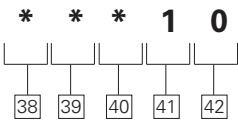

38 39 40 Special Features

000 – None

??? – Defined by Eaton

41 42 Design Number

10 – Design Number

Motor Specifications - U.S.

MODEL			MFW / MVW 66	MFW / MVW 90	MFW / MVW 130	MFW / MVW 180
Design			swashplate type			
Type of mounting			Flange- or foot-mounted. Combination units foot mounted only.			
Pipe connection SAE Flange	B A	psi	1" = 6000 1" = 6000	1" = 6000 1" = 6000	1" = 6000 1" = 6000	1 1/4" = 6000 1 1/4" = 6000
Direction of rotation			Bi - directional			
Speed range	$n_{min}^{1)}$ $n_{max}^{2)}$	rpm	80 1800			
Installation position			Optional, see mounting information			
Ambient temperature range	min max	°F	-4 122			
Weight	M	lbs.	121	165	234	251
Mass of inertia	J	lb ft ²	0.38	0.38	1.068	1.068

HYDRAULIC CHARACTERISTICS

Nominal pressure (100% duty cycle)	p_N	psi	5000			
Output pressure	p_{Amin} / p_{Bmin} p_{Bmax} / p_{Amax}	psi	30 Pressure can be applied to the motor outlet but the sum of p_{Amax} and p_{Bmax} must not exceed the maximum value of 6090psi			
Maximum pressure to DIN 24312	p_{max}	psi	6090			
Hydraulic fluid			Hydraulic oil to DIN 51524 part 2. Refer to section Application Data-Fluid Recommendations			
Hydraulic fluid temperature range	min max	°F	-13 (on startup) 194			
Viscosity range for continuous operation	min max	cSt cSt	10 75			
Maximum permissible start viscosity	max	cSt	1000			
Filtering	ISO 4406		18/15/13			
Maximum geometric absorption rate ³⁾	V_{gmax}	in ³	4.1	5.5	7.9	11.0
Minimum geometric absorption rate	V_{gmin}	in ³	When no minimum adjustment stop is specified, min. geometric absorption rate is set at 35% of V_{gmax}			
Maximum geometric motor flow	Q_g	USgpm	31.4	42.8	61.8	85.6
Case pressure	p_{Vmax}	psi	max. 7.2psi over p_{Amin} / p_{Bmin} , $p_{Vmax} = 58$ psi abs., $p_{Vmax} = 87$ psi abs. with special shaft seal			

DRIVE

Maximum driving torque - (p_{Amax} or p_{Bmax} , $\eta = 100\%$)	M1 single	lb.ft	325	444	640	887
Maximum power consumption - $n=1800$ rpm (p_{Amax} or p_{Bmax} , $\eta = 100\%$)	P1 single	hp	112	152	220	304

COMBINATION UNITS

Maximum driving torque - comb. unit (splined shaft only)	M1	lb.ft	2x 325	2x 444	2x 640	2x 887
---	----	-------	--------	--------	--------	--------

- 1) Minimum speed for continuous operation
- 2) Higher speed available on request
- 3) Tolerance + 1%

Motor Specifications - Metric

MODEL			MFW / MVW 66	MFW / MVW 90	MFW / MVW 130	MFW / MVW 180
Design			swashplate type			
Type of mounting			Flange or foot-mounted. Combination units foot mounted only.			
Pipe connection SAE Flange	B A	psi	1" = 6000 1" = 6000	1" = 6000 1" = 6000	1" = 6000 1" = 6000	1 1/4" = 6000 1 1/4" = 6000
Direction of rotation			Bi - directional			
Speed range	$n_{min}^{1)}$ $n_{max}^{2)}$	min ⁻¹	80 1800			
Installation position			Optional, see mounting information			
Ambient temperature range	min max	°C	-20 50			
Weight	M	kg	55	75	106	114
Mass of inertia	J	kg m ²	0,016	0,016	0,045	0,045

HYDRAULIC CHARACTERISTICS

Nominal pressure (100% duty cycle)	p_N	bar	350			
Output pressure	p_{Amin} / p_{Bmin} p_{Bmax} / p_{Amax}	bar	2 Pressure can be applied to the motor outlet but the sum of p_{Amax} and p_{Bmax} must not exceed the maximum value of 420 bar			
Maximum pressure to DIN 24312	p_{max}	bar	420			
Hydraulic fluid			Hydraulic oil to DIN 51524 part 2. Refer to section Application Data-Fluid Recommendations			
Hydraulic fluid temperature range	min max	°C	-25 (on startup) 90			
Viscosity range for continuous operation	min max	cSt cSt	10 75			
Maximum permissible start viscosity	max	cSt	1000			
Filtering	ISO 4406		18/15/13			
Maximum geometric absorption rate ³⁾	V_{gmax}	cm ³	66	90	130	180
Minimum geometric absorption rate	V_{gmin}	cm ³	When no minimum adjustment stop is specified, min. geometric absorption rate is set at 35% of V_{gmax}			
Maximum geometric motor flow	Q_g	l / min	119	162	234	324
Case pressure	p_{vmax}	bar	max. 0.5 bar over p_{Amin} / p_{Bmin} , $p_{vmax} = 4$ bar abs., $p_{vmax} = 6$ bar abs. with special shaft seal			

DRIVE

Maximum driving torque - single unit (p_{Amax} or p_{Bmax} , $\eta = 100\%$)	M1 Single	Nm	441	602	869	1203
Maximum power consumption - $n=180$ min ⁻¹ (p_{Amax} or p_{Bmax} , $\eta = 100\%$)	P1 Single	kW	83	114	164	227

COMBINATION UNITS

Maximum driving torque - comb. unit (splined shaft only)	M1	Nm	2x441	2x602	2x869	2x1203
---	----	----	-------	-------	-------	--------

1) Minimum speed for continuous operation

2) Higher speed available on request

3) Tolerance + 1%

Electric Motor Displacement Control ES

"X" Series - Motors

This ES control adjusts the swashplate angle of the pump by means of a three phase electric servo motor, worm gearing and a switch box with 4 or (optional) 8 limit switches for different positions. A potentiometer for stepless adjustment and/or position monitoring is also available.

The response times from zero to maximum depends on the chosen ratio and the (fixed) speed of the servo motor (this means that once the control is defined and built the response times are not variable during operation).

Explosion protection versions are also available.

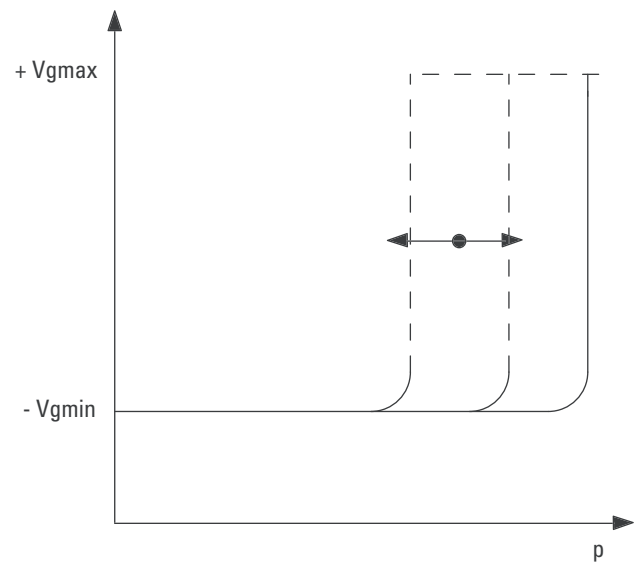
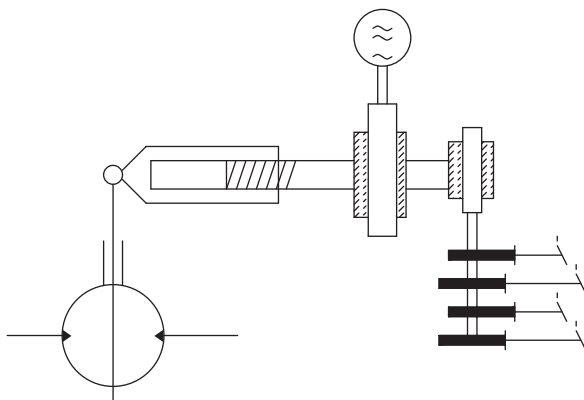
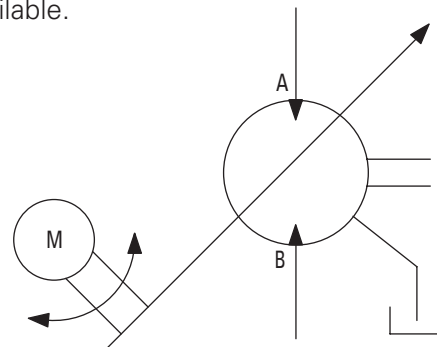

MVX Response times ES - Control

Size	THEORETICAL RESPONSE TIME (SEC) FOR MAXIMUM DISPLACEMENT				CHARACTER IN MODEL CODE POS.25	
	066 / 090		130 / 180		250	
Frequency Hz	50	60	50	60	50	60
Fast	5	4	12	10	10	9
Medium	16	13	23	19	20	16
Slow	25	21	35	30	31	26

Response time from V_{gmin} (35%) to $+V_{gmax}$ (100%)

FE, HG Manual Adjustment Displacement Control

"X" Series - Motors

FE The FE control is a displacement control where the motor's swashplate angle is adjusted by a screw.

HG The HG control is a displacement control where the motor's swashplate angle can be adjusted by a handwheel.

The max. (and/or min.) swashplate angle can be limited by a spacer inside the control cylinder (pos. no. 13 in model coding, options 4, 5 or 6 in combination

with customer adjustment specification in position 34-37 for the set values). The setting must be defined before ordering and cannot be modified during operation.

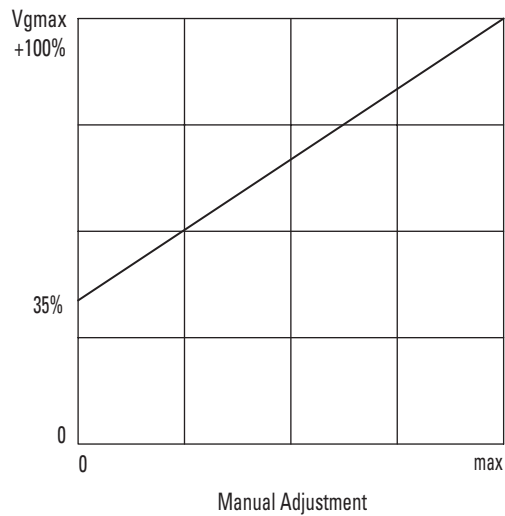
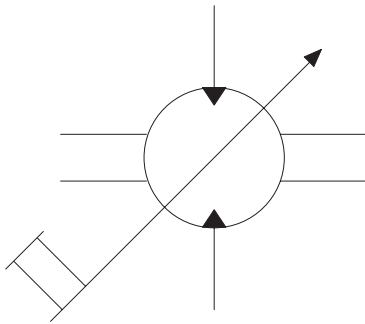

DP Pressure Signal Adjustment Displacement Control

"X" Series - Motors

The swivel angle of the motor is proportional to the pilot pressure.

A separate pilot oil circuit is necessary. This circuit should be external to prevent the influence of variable motor speed to the pilot oil flow i.e. response time. From this the control pressure is reduced to the desired set value by means of a suitable pressure control valve (with P-T line) and throttle in P line 0.8 Ø (0.03 in).

The DP control can be used for stepless adjustment of the swashplate angle with standard requirements in dynamic and precision. No feedback signal is needed, an optical indicator recommended (pos. 21 in model coding, option "V").

The maximum swashplate angle of the motor can be limited mechanically to between 50% and 100% by a screw. As an additional option the max. (and/or min.) value can be limited by a spacer inside the control cylinder (pos. no. 13 in model coding, options 4, 5 or 6 in combination with customer adjustment specification in position 34-37 for the set values).

This solution is also recommended for very rough operating conditions and the need of a very exact repeatability over a long time period. The setting must be defined before ordering and cannot be modified during operation.

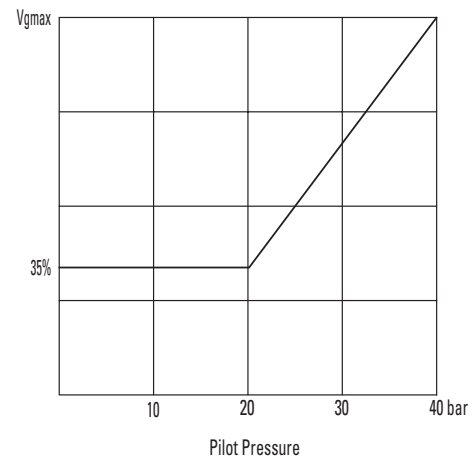
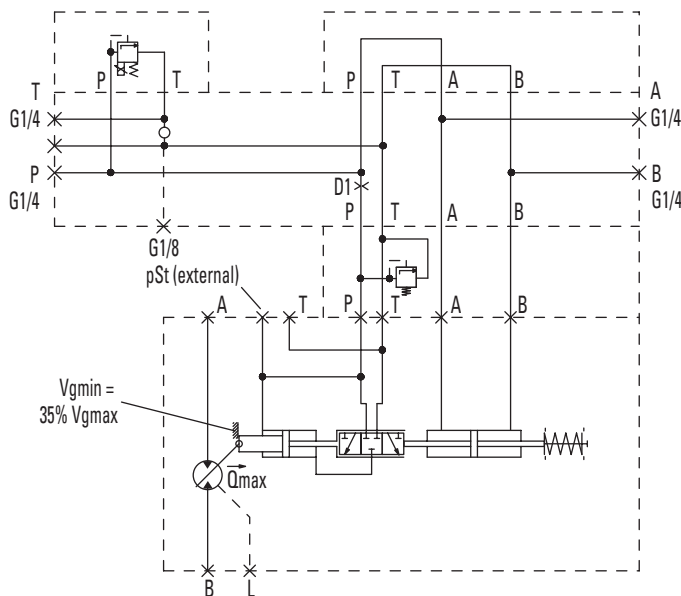

SIZE	RESPONSE TIME (SEC) WITH 12 L/MIN PILOT OIL FLOW (STANDARD)	PILOT PRESSURE PST (BAR)
066/090	0,5	60
130/180	0,7	60
250	0,9	60

Response time from Vgmin (35%) to +Vgmax (100%)

Electrohydraulic Servo Adjustment "SP"

"X" Series - Motors

The Electro hydraulic displacement control works without throttle losses within electrically adjustable limits. This is done by controlling swashplate angle with electrical feedback (electrical closed loop control). A separate pilot oil circuit is necessary. This circuit should be external to prevent the influence of variable

motor speed to the pilot oil flow i.e. response time. The swashplate angle is recorded as an electrical signal and lead back to the control card. The proportional valve and servo piston transform the output signal of the control card to the desired setting. This results in very precise and dynamic control.

Hysteresis, consistency: approximately 1% of end value.

The maximum swashplate angle of the motor can be limited mechanically to between 50% and 100% by screw. As an additional option the max. (and/or min.) flow can be limited by a spacer inside the control cylinder (pos. no. 13 in model coding, options 4, 5 or 6 in

combination with customer adjustment specification in position 40-43 for the set values). This solution is also recommended for very rough operating conditions and the need for very exact repeatability over a long time period. The setting must be defined before ordering and cannot be modified during operation.

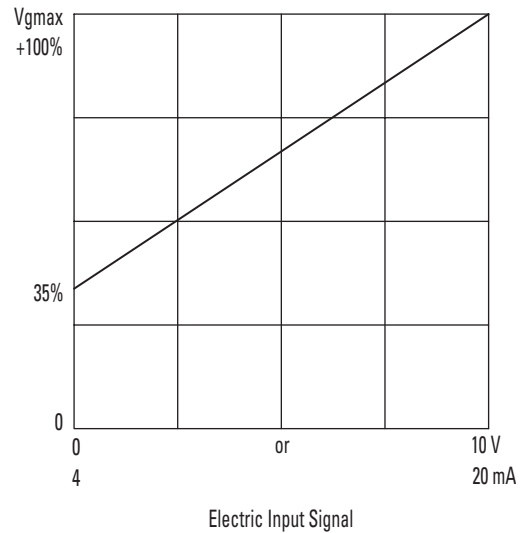
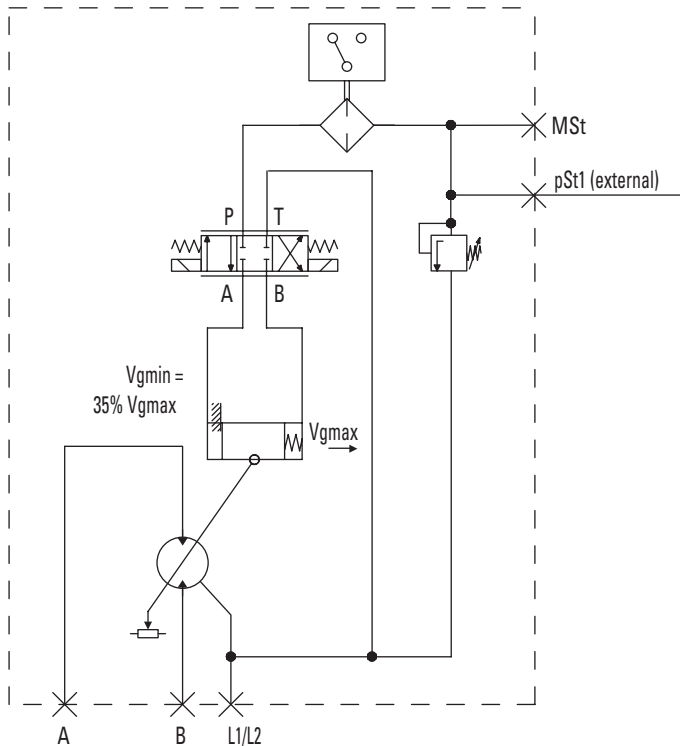

Electrohydraulic Servo Adjustment "SP" (Cont.)

"X" Series - Motors

Response Times - Electronic Control Cards

PROPORTIONAL VALVE	PILOT OIL FLOW L/MIN (USGPM)	PILOT OIL PRESSURE PST BAR (PSI)	CONTROL ELECTRONICS (AMP. CARD)	RESPONSE	UNIT SIZE CM ³	SERVO PISTON DIAMETER MM (IN)	STROKE MM (IN)	VOLUME CM ³ (IN ³) PER CHAMBER
				TIME VMIN< >VMAX [MS]				
Medium response		60 (857)		170	066 / 090	40 / 30 (1.57 / 1.18)	18 (.71)	10,0 (.611)
KDG4V3-2 C20NMUH760 (CETOP3)	12 (3.17)	60 (857)	ER9.3-10	230	130 / 180	55 / 38 (2.16 / 1.49)	23 (.89)	28,3 (1.725)
High response (CETOP5)	On request	60 (857)		375	250	70 / 50 (2.76 / 1.97)	28 (1.11)	52,6 (3.213)

The ER9.3-10 and ER 9.4-10 (for High Response) digital Amplifier cards are optimized for use with the SP - Control. Please ask for separate Documentation. Software is available for parameter setting and storing (database function). Contact Eaton to request free of charge manual and software CD.

Dimensions - MFXS 066, 090, 130, 180

- L1 Drainage resp. filling of the housing
- MA Gauge port G1/4"
- MB Gauge port G1/4"

Non-Standard Displacement:

SIZE	REDUCED DISPLACEMENT AVAILABLE
066	55 or 44 ccm / rev
090	75 or 60 ccm / rev
130	115 or 94 ccm / rev
180	160 or 130 ccm / rev

DIRECTION OF ROTATION	INLET PORT (HIGH PRESSURE SIDE)	OUTLET PORT (LOW PRESSURE SIDE)
Right Hand Rotation	B	A
Left Hand Rotation	A	B

SIZE	SAE-FLANGE 6000PSI
066	1"
090	1"
130	1"
180	1 1/4"

SIZE	B1	B2	B3	B4	B6	B7 h9
066	210	175	120	155	180	10
090	210	175	120	155	180	10
130	260	240	150	200	224	14
180	260	240	150	200	224	14

SIZE	D1 h8	D2 k6	D3	D4	D5	D6 Light Execution	D7 DEEP	D8 DEEP	D9	D10	D11	D12	D13
066	125	38	M12	18	M10	M26x1.5	M10 20	M12 18	25	R1/4"	W40x1.25x10a	R1/4"	M26x1.5
090	125	38	M12	18	M10	M26x1.5	M10 20	M12 18	25	R1/4"	W40x1.25x10a	R1/4"	M26x1.5
130	160	50	M16	22	M10	M26x1.5	M12 20	M12 20	25	R1/4"	W50x1.25x10a	R1/4"	11/16-12 UNF
180	160	50	M16	22	M10	M26x1.5	M12 20	M14 25	30	R1/4"	W50x1.25x10a	R1/4"	11/16-12 UNF

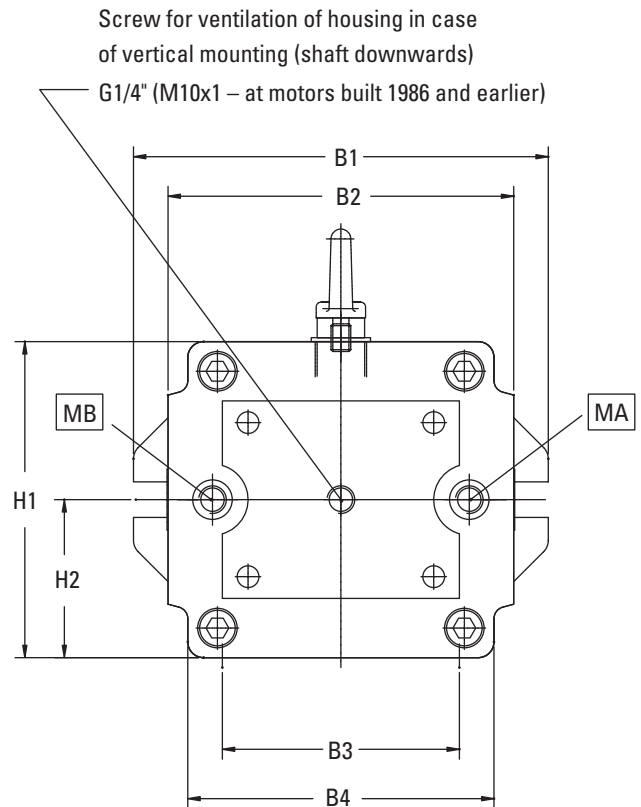

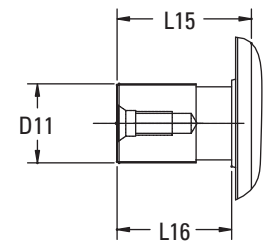
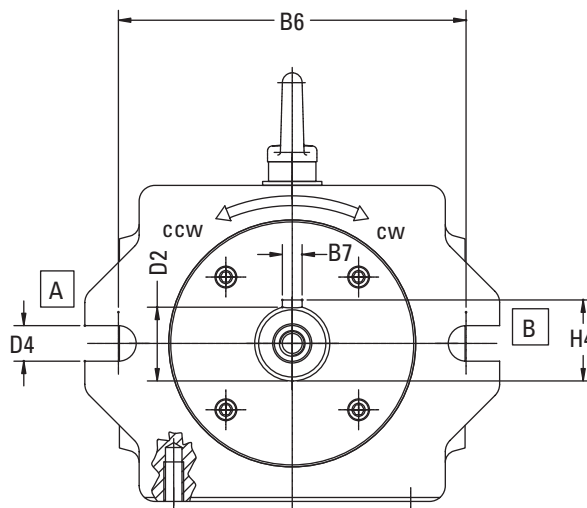
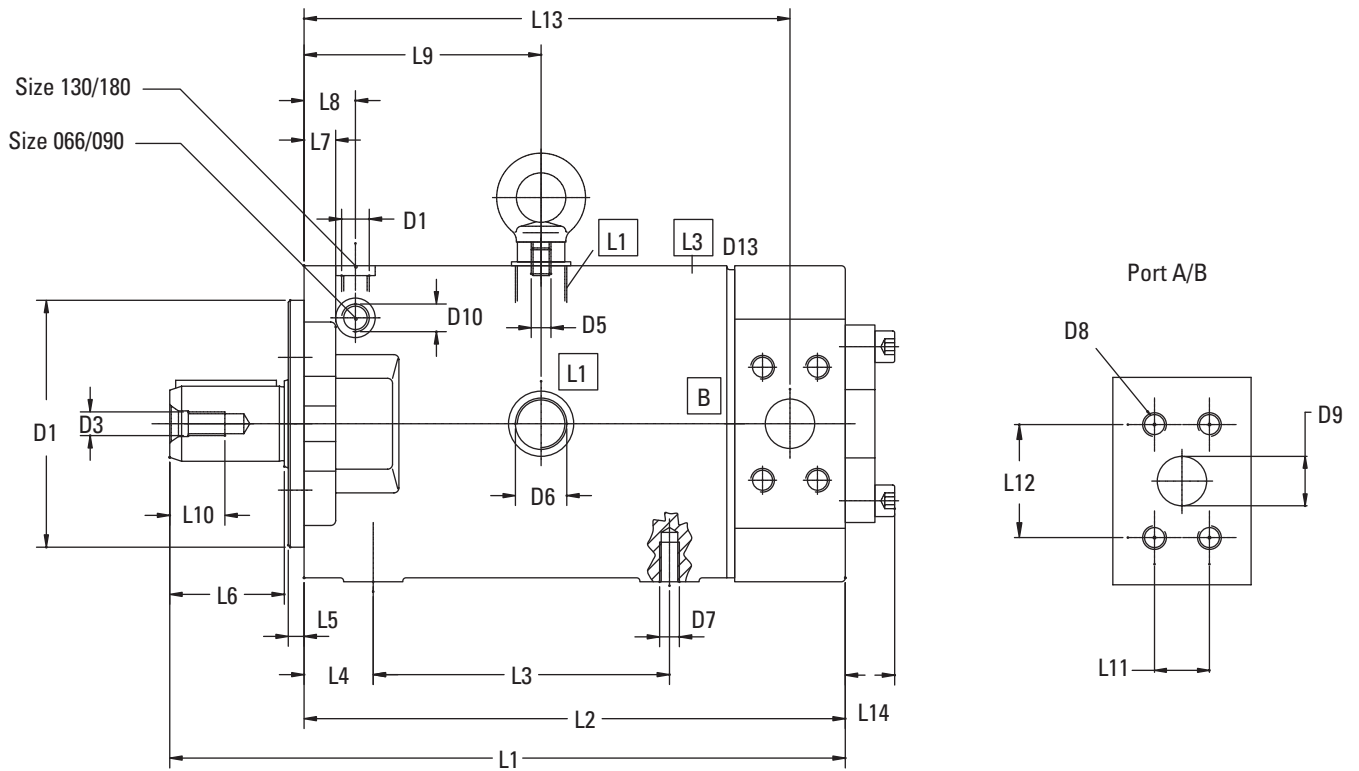

SIZE	H1	H2	H4
066	160	80	41
090	160	80	41
130	200	100	53.5
180	200	100	53.5

SIZE	L1	L2	L3	L4	L5	L6	L7	L8	L9	L10	L11	L12	L13	L14
066	342	274	150	35	8	58	16	26	120	28	27.8	57.2	246	—
090	342	274	150	35	8	58	16	26	120	28	27.8	57.2	246	—
130	433	341	185	40	9	82	20	32	148	36	27.8	57.2	306	26
180	433	341	185	40	9	82	20	32	148	36	31.8	66.7	306	26

Dimensions - MVXS 066, 090, 130, 180

Displacement Control
By Electric Motor, ES

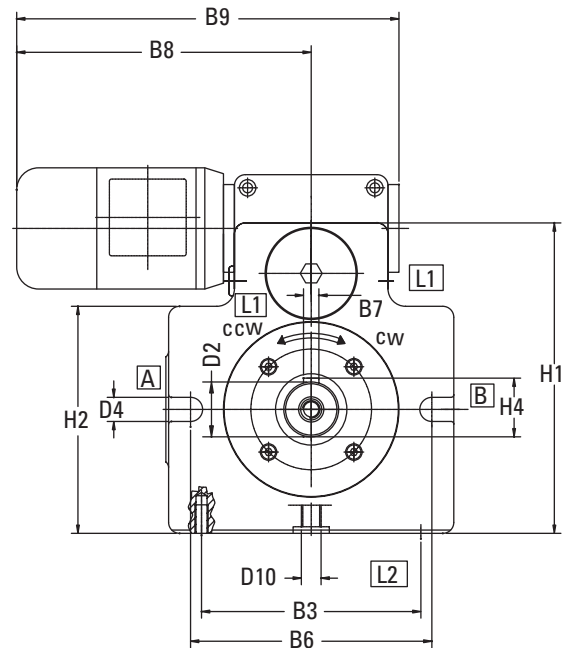
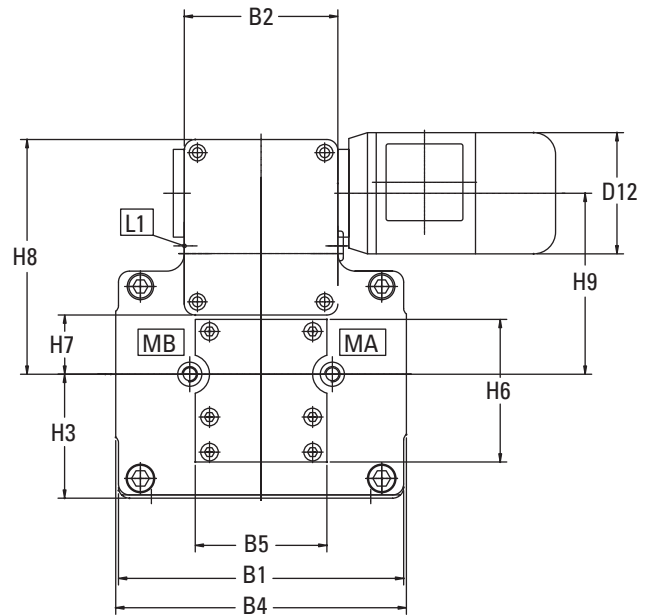

- L1 Two drain ports, one supplied plugged.
- L2 Supplementary drain or bleed plug. Must be drained in addition to L1 if the pump is installed with the shaft input end pointing upwards.
- L3 Oil filling or bleed plug. Must be drained in addition to L1 if the pump is installed with the shaft input end pointing downwards.
- MA Gauge port G1/4"
- MB Gauge port G1/4"

DIRECTION OF ROTATION	INLET PORT (HIGH PRESSURE SIDE)	OUTLET PORT (LOW PRESSURE SIDE)
Right Hand Rotation	B	A
Left Hand Rotation	A	B

SIZE	B1	B2	B3	B4	B5	B6	B7 h9	B8	B9
066	210	116	160	235	120	180	10	276.5	334.5
090	210	116	160	235	120	180	10	276.5	334.5
130	260	140	200	265	120	224	14	288.5	368.5
180	260	140	200	265	120	224	14	288.5	368.5

SIZE	D1 h8	D2 k6	D3	D4	D5	D6 Light Execution	D7 DEEP	D8 DEEP	D9	D10 DEEP	D11	D12	D13 SAEJ475
066	125	38	M12	18	M10	M22x1.5	M10 20	M12 18	25	M18x1.5 12	VW40x1.25x10a	110.5	7/8-14 UNF
090	125	38	M12	18	M10	M22x1.5	M10 20	M12 20	25	M18x1.5 12	VW40x1.25x10a	110.5	7/8-14 UNF
130	160	50	M16	22	M10	M26x1.5	M12 26	M12 20	25	M18x1.5 12	VW50x1.25x10a	110.5	11/16-12 UNF
180	160	50	M16	22	M10	M26x1.5	M12 26	M14 22	30	M18x1.5 12	VW50x1.25x10a	110.5	11/16-12 UNF

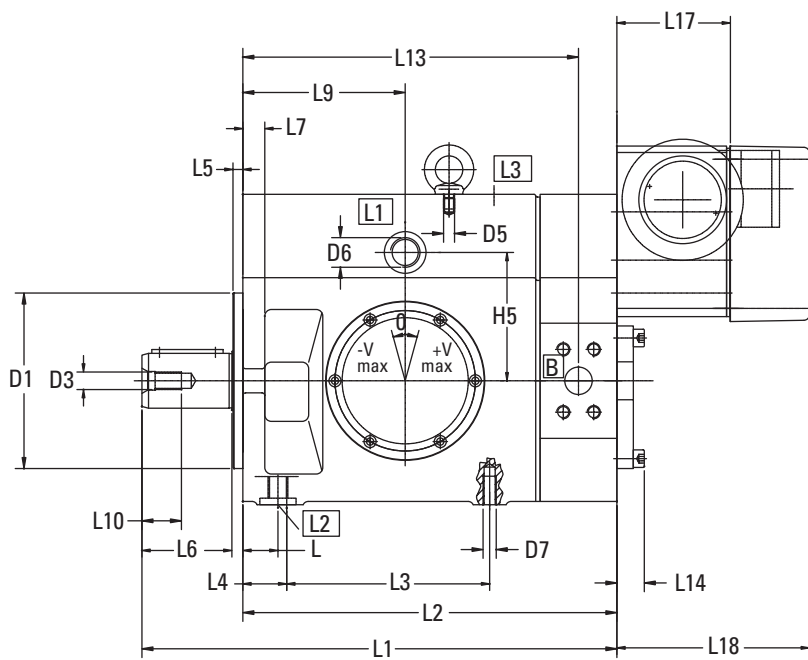

For Splined Data See Table

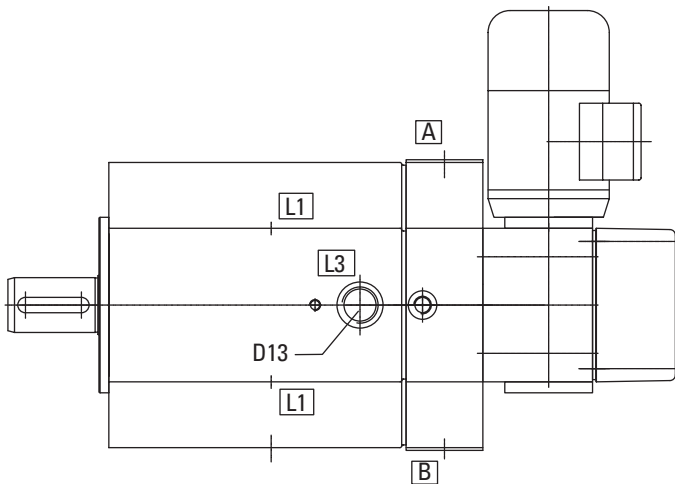
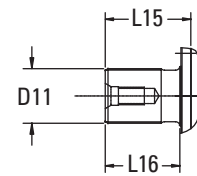

Port A/B

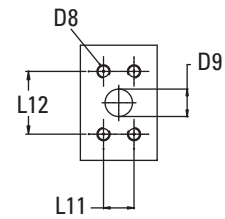

SIZE	H1	H2	H3	H4	H5	H6	H7	H8	H9
066	227	162	90	41	93	130	53	168	122
090	227	162	90	41	93	130	53	168	122
130	283	207	113	53.5	117	130	58.5	214	165
180	283	207	113	53.5	117	130	58.5	214	165

SIZE	L1	L2	L3	L4	L5	L6	L7	L8	L9	L10	L11	L12	L13	L14	L15	L16	L17	L18
066	342	274	150	35	8	58	16	26	120	28	27.8	57.2	245.6	25	68	58	78	153.5
090	342	274	150	35	8	58	16	26	120	28	27.8	57.2	245.6	25	68	58	78	153.5
130	433	341	185	40	9	82	20	32	148	36	27.8	57.2	306	26	78	68	100	175.5
180	433	341	185	40	9	82	20	32	148	36	27.8	57.2	306	26	78	68	100	175.5

Dimensions - MVXS 066, 090, 130, 180

Handwheel Control, HG

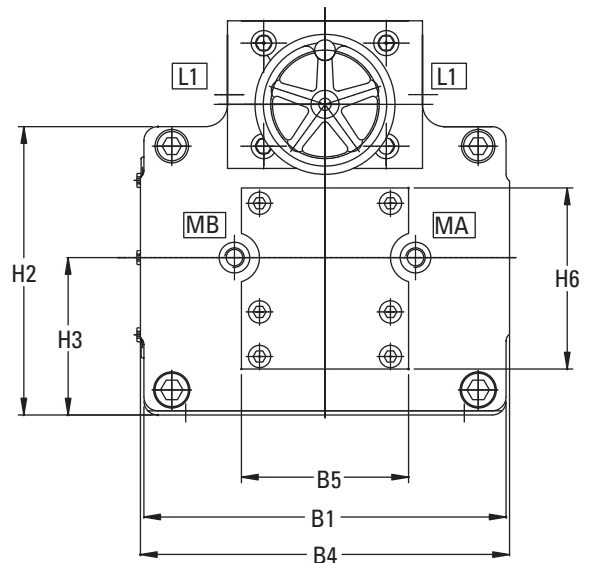

- L1 Two drain ports, one supplied plugged.
- L2 Supplementary drain or bleed plug. Must be drained in addition to L1 if the pump is installed with the shaft input end pointing upwards.
- L3 Oil filling or bleed plug. Must be drained in addition to L1 if the pump is installed with the shaft input end pointing downwards.
- MA Gauge port G1/4"
- MB Gauge port G1/4"

DIRECTION OF ROTATION	INLET PORT (HIGH PRESSURE SIDE)	OUTLET PORT (LOW PRESSURE SIDE)
Right Hand Rotation	B	A
Left Hand Rotation	A	B

SIZE	SAE-FLANGE 6000PSI
066	1"
090	1"
130	1"
180	1 1/4"

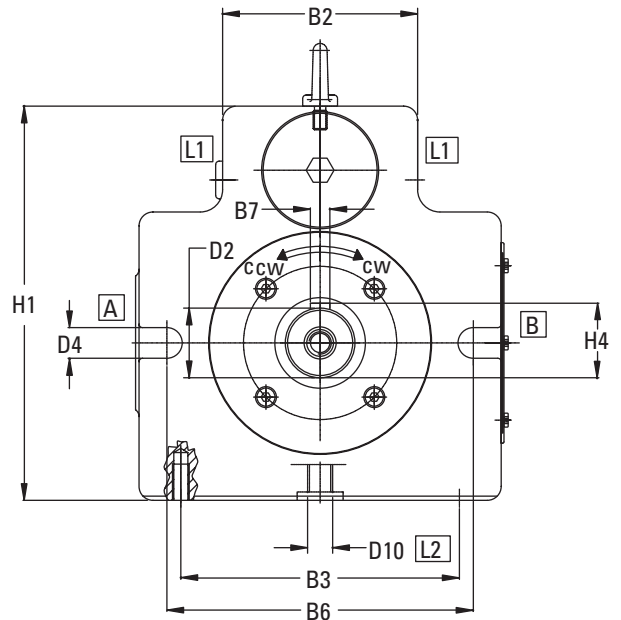

SIZE	B1	B2	B3	B4	B5	B6	B7 h9
066	210	116	160	235	120	180	10
090	210	116	160	235	120	180	10
130	260	140	200	265	120	224	14
180	260	140	200	265	120	224	14

SIZE	D1 h8	D2 k6	D3	D4	D5	D6 Light Execution	D7 DEEP	D8 DEEP	D9	D10 DEEP	D11	D12 SAEJ475
066	125	38	M12	18	M10	M22x1.5	M10 20	M12 18	25	M18x1.5 12	W40x1.25x10a	7/8-14 UNF
090	125	38	M12	18	M10	M22x1.5	M10 20	M12 20	25	M18x1.5 12	W40x1.25x10a	7/8-14 UNF
130	160	50	M16	22	M10	M26x1.5	M12 26	M12 20	25	M18x1.5 12	W50x1.25x10a	11/16-12 UNF
180	160	50	M16	22	M10	M26x1.5	M12 26	M14 22	30	M18x1.5 12	W50x1.25x10a	11/16-12 UNF

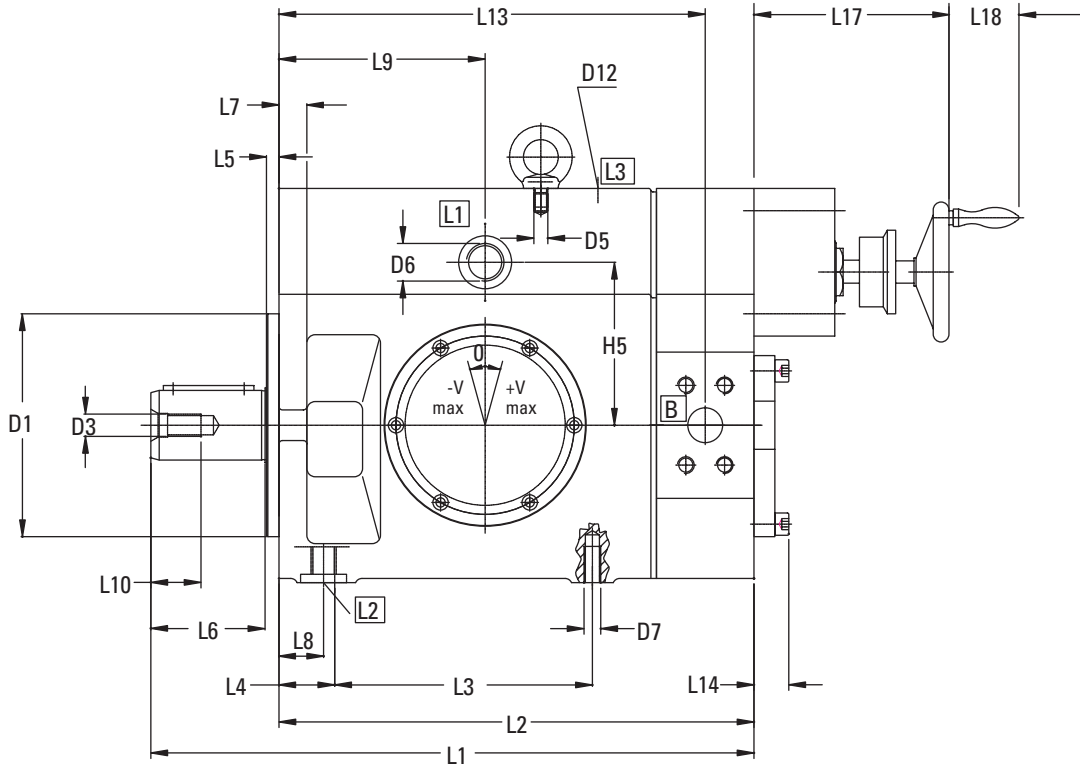

For Splined Data See Table

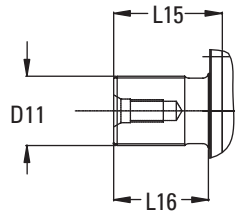

Port A/B

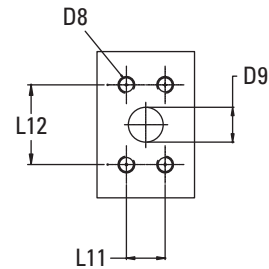

SIZE	H1	H2	H3	H4	H5	H6
066	227	162	90	41	93	130
090	227	162	90	41	93	130
130	283	207	113	53.5	117	130
180	283	207	113	53.5	117	130

SIZE	L1	L2	L3	L4	L5	L6	L7	L8	L9	L10	L11	L12	L13	L14	L15	L16	L17	L18
066	342	274	150	35	8	58	16	26	120	28	27.8	57.2	245.6	25	68	58	130	46
090	342	274	150	35	8	58	16	26	120	28	27.8	57.2	245.6	25	68	58	130	46
130	433	341	185	40	9	82	20	32	148	36	27.8	57.2	306	26	78	68	130	46
180	433	341	185	40	9	82	20	32	148	36	31.8	66.2	306	26	78	68	130	46

Dimensions - MVXS 066, 090, 130, 180

Adjustment Screw Control, FE

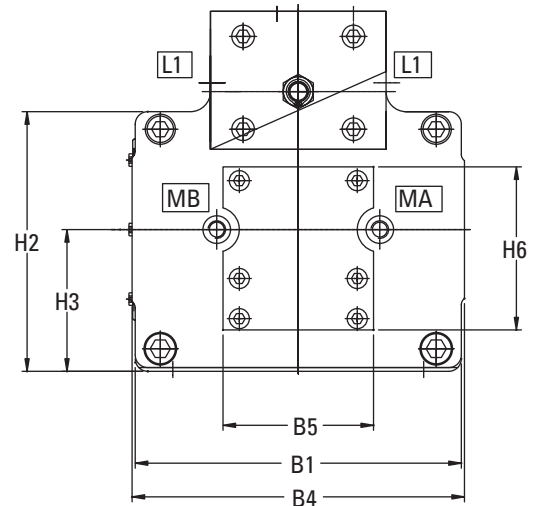

- L1 Two drain ports, one supplied plugged.
- L2 Supplementary drain or bleed plug. Must be drained in addition to L1 if the pump is installed with the shaft input end pointing upwards.
- L3 Oil filling or bleed plug. Must be drained in addition to L1 if the pump is installed with the shaft input end pointing downwards.
- MA Gauge port G1/4"
- MB Gauge port G1/4"

DIRECTION OF ROTATION	INLET PORT (HIGH PRESSURE SIDE)	OUTLET PORT (LOW PRESSURE SIDE)
Right Hand Rotation	B	A
Left Hand Rotation	A	B

SIZE	SAE-FLANGE 6000PSI
066	1"
090	1"
130	1"
180	1 1/4"

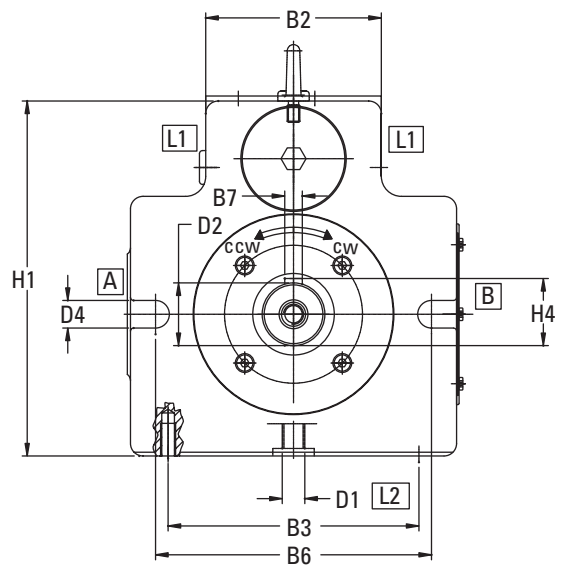

SIZE	B1	B2	B3	B4	B5	B6	B7 h9
066	210	116	160	235	120	180	10
090	210	116	160	235	120	180	10
130	260	140	200	265	120	224	14
180	260	140	200	265	120	224	14

SIZE	D1 h8	D2 k6	D3	D4	D5	D6 Light Execution	D7 DEEP	D8 DEEP	D9	D10 DEEP	D11	D12 SAEJ475
066	125	38	M12	18	M10	M22x1.5	M10 20	M12 18	25	M18x1.5 12	W40x1.25x10a	7/8-14 UNF
090	125	38	M12	18	M10	M22x1.5	M10 20	M12 20	25	M18x1.5 12	W40x1.25x10a	7/8-14 UNF
130	160	50	M16	22	M10	M26x1.5	M12 26	M12 20	25	M18x1.5 12	W50x1.25x10a	11/16-12 UNF
180	160	50	M16	22	M10	M26x1.5	M12 26	M14 22	30	M18x1.5 12	W50x1.25x10a	11/16-12 UNF

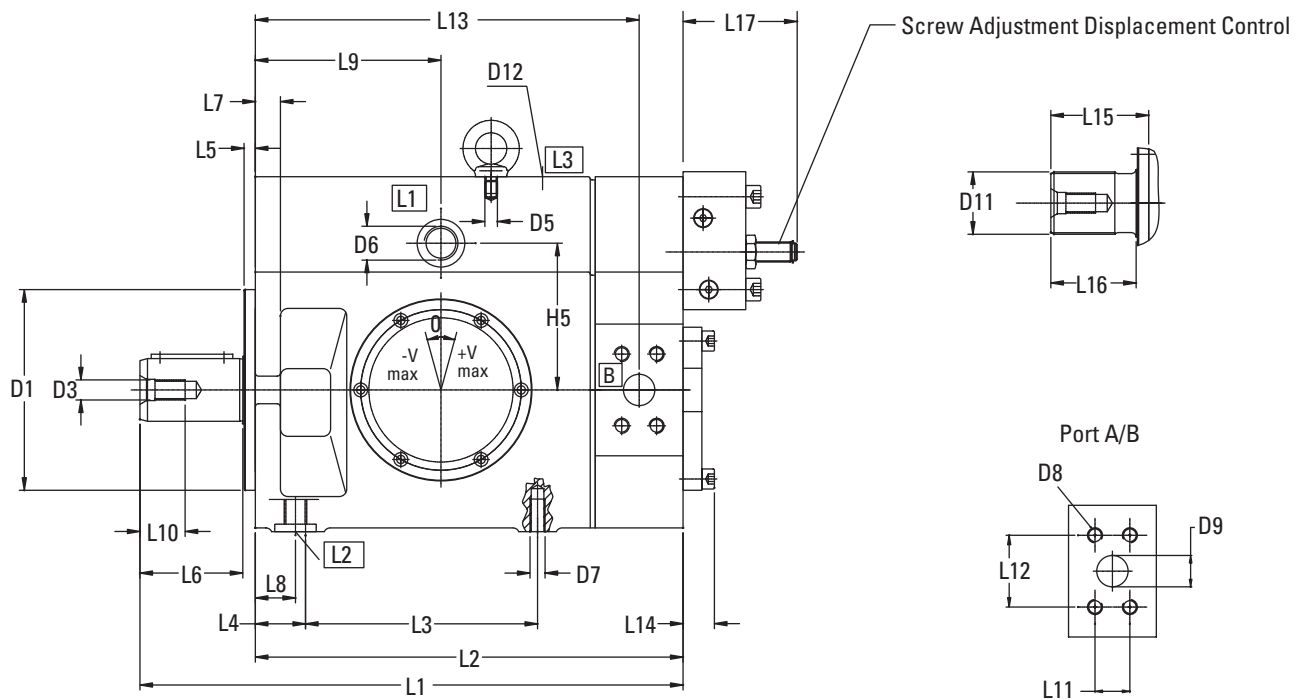

SIZE	H1	H2	H3	H4	H5	H6
066	227	162	90	41	93	130
090	227	162	90	41	93	130
130	283	207	113	53.5	117	130
180	283	207	113	53.5	117	130

SIZE	L1	L2	L3	L4	L5	L6	L7	L8	L9	L10	L11	L12	L13	L14	L15	L16	L17
066	342	274	150	35	8	58	16	26	120	28	27.8	57.2	245.6	25	68	58	90
090	342	274	150	35	8	58	16	26	120	28	27.8	57.2	245.6	25	68	58	90
130	433	341	185	40	9	82	20	32	148	36	27.8	57.2	306	26	78	68	90
180	433	341	185	40	9	82	20	32	148	36	31.8	66.2	306	26	78	68	90

Dimensions - MVXS 066, 090, 130, 180

Pressure Signal
Displacement Control, DP

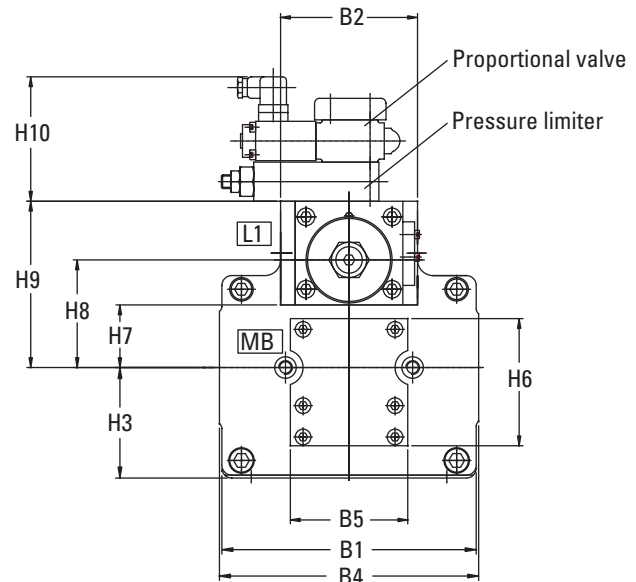

- T Return line of control circuit G1/2"
- L1 Two drain ports, one supplied plugged.
- L2 Supplementary drain or bleed plug. Must be drained in addition to L1 if the pump is installed with the shaft input end pointing upwards.
- L3 Oil filling or bleed plug. Must be drained in addition to L1 if the pump is installed with the shaft input end pointing downwards.
- MA Gauge port system pressure G1/4"
- MB Gauge port system pressure G1/4"

DIRECTION OF ROTATION	INLET PORT (HIGH PRESSURE SIDE)	OUTLET PORT (LOW PRESSURE SIDE)
Right Hand Rotation	B	A
Left Hand Rotation	A	B

SIZE	SAE-FLANGE 6000PSI
066	1"
090	1"
130	1"
180	1 1/4"

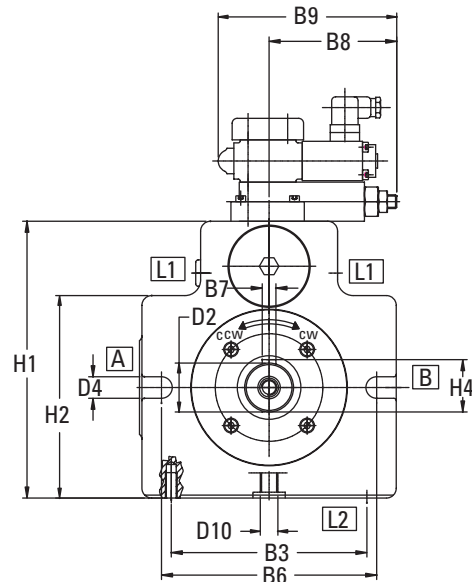

SIZE	B1	B2	B3	B4	B5	B6	B7 h9	B8	B9
066	210	116	160	235	120	180	10	130.5	182.5
090	210	116	160	235	120	180	10	130.5	182.5
130	260	140	200	265	120	224	14	130.5	182.5
180	260	140	200	265	120	224	14	130.5	182.5

SIZE	D1 h8	D2 k6	D3	D4	D5	D6 Light Execution	D7 DEEP	D8 DEEP	D9	D10 DEEP	D11	D12	D13 SAEJ475
066	125	38	M12	18	M10	M22x1.5	M10 20	M12 18	25	M18x1.5 12	W40x1.25x10a	64	7/8-14 UNF
090	125	38	M12	18	M10	M22x1.5	M10 20	M12 20	25	M18x1.5 12	W40x1.25x10a	64	7/8-14 UNF
130	160	50	M16	22	M10	M26x1.5	M12 26	M12 20	25	M18x1.5 12	W50x1.25x10a	88	1 1/16-12 UNF
180	160	50	M16	22	M10	M26x1.5	M12 26	M14 22	30	M18x1.5 12	W50x1.25x10a	88	1 1/16-12 UNF

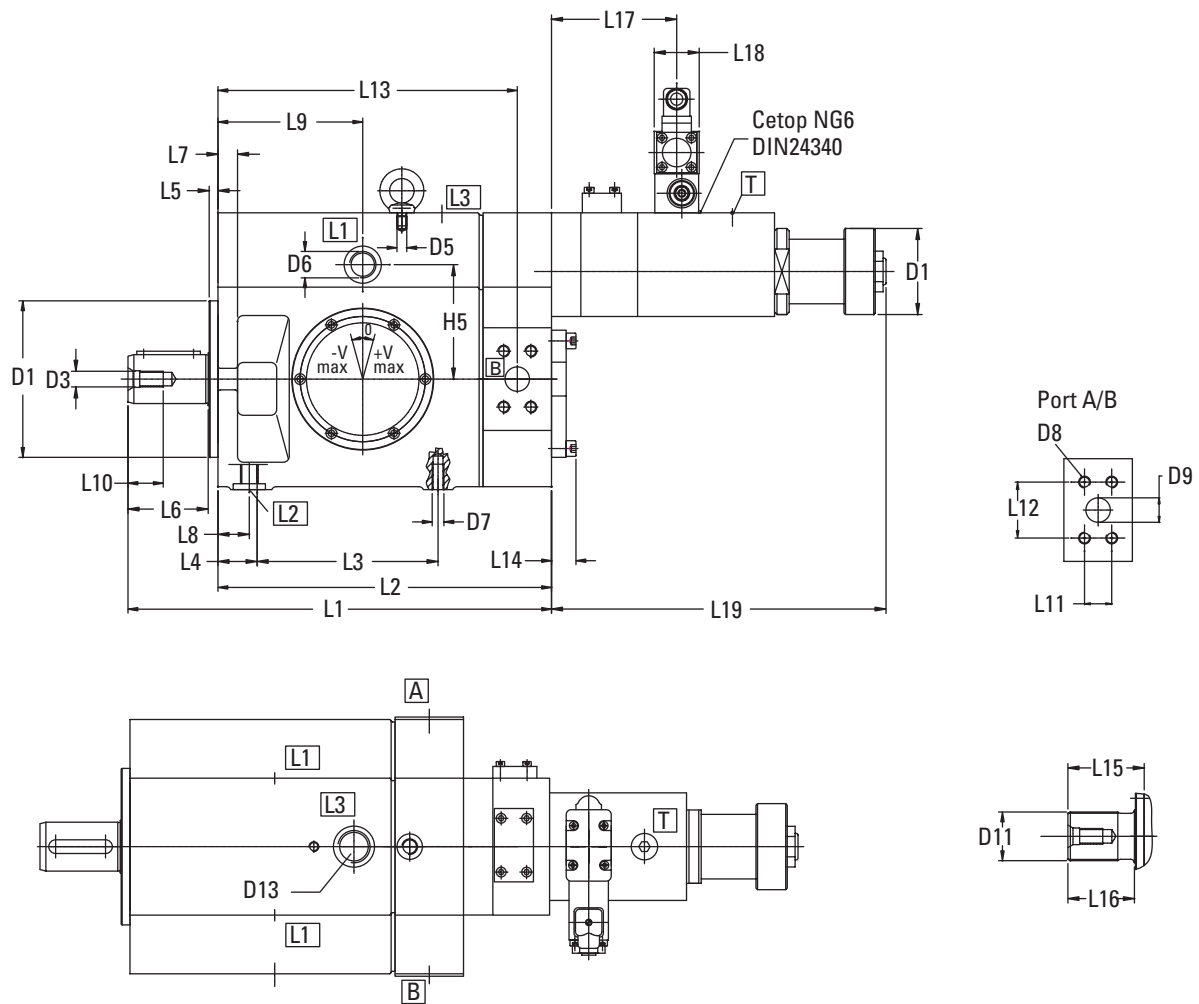

SIZE	H1	H2	H3	H4	H5	H6	H7	H8	H9	H10
066	227	162	90	41	93	130	53	88	137	127
090	227	162	90	41	93	130	53	88	137	127
130	283	207	113	53.5	117	130	64	110	170	127
180	283	207	113	53.5	117	130	64	110	170	127

SIZE	L1	L2	L3	L4	L5	L6	L7	L8	L9	L10	L11	L12	L13	L14	L15	L16	L17	L18	L19
066	342	274	150	35	8	58	16	26	120	28	27.8	57.2	245.6	25	68	58	104	46	267
090	342	274	150	35	8	58	16	26	120	28	27.8	57.2	245.6	25	68	58	104	46	267
130	433	341	185	40	9	82	20	32	148	36	27.8	57.2	306	26	78	68	128	46	342
180	433	341	185	40	9	82	20	32	148	36	31.8	66.7	306	26	78	68	128	46	342

Dimensions - MVXS 066, 090, 130, 180

**Electro Hydraulic
Displacement Control, SP**

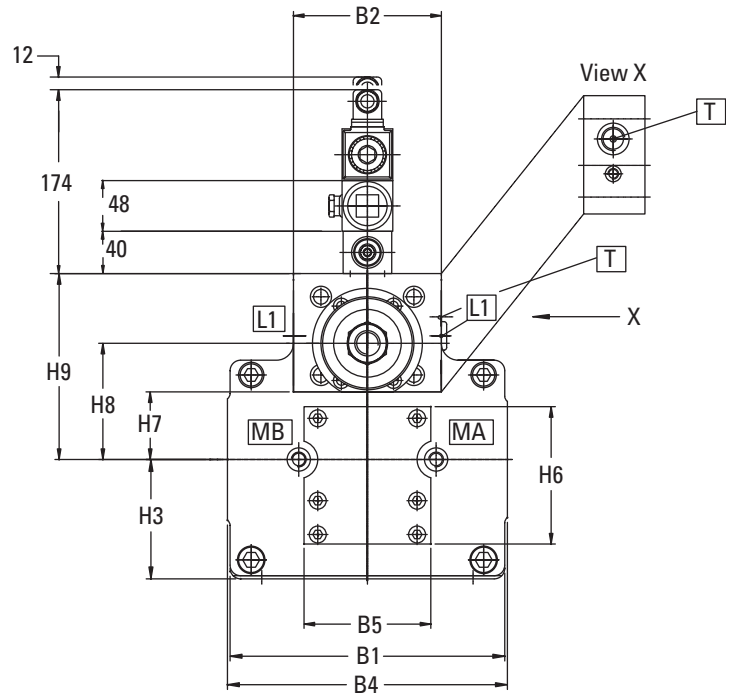

- [A] System pressure port (see detail)
- [B] System pressure port (see detail)
- [L1] Two drain ports, one supplied plugged.
- [L2] Supplementary drain or bleed plug. Must be drained in addition to [L1] if the pump is installed with the shaft input end pointing upwards.
- [L3] Oil filling or bleed plug. Must be drained in addition to [L1] if the pump is installed with the shaft input end pointing downwards.
- [MA] Gauge port system pressure G1/4"
- [MB] Gauge port system pressure G1/4"
- [MSt] Gauge port pilot pressure G1/4"
- [PSt2] Pilot pressure port G1/2"
- [T] Return line of control circuit G1/2"
- (...) Normally plugged

DIRECTION OF ROTATION	INLET PORT (HIGH PRESSURE SIDE)	OUTLET PORT (LOW PRESSURE SIDE)
Right Hand Rotation	B	A
Left Hand Rotation	A	B

SIZE	SAE-FLANGE 6000PSI
066	1"
090	1"
130	1"
180	1 1/4"

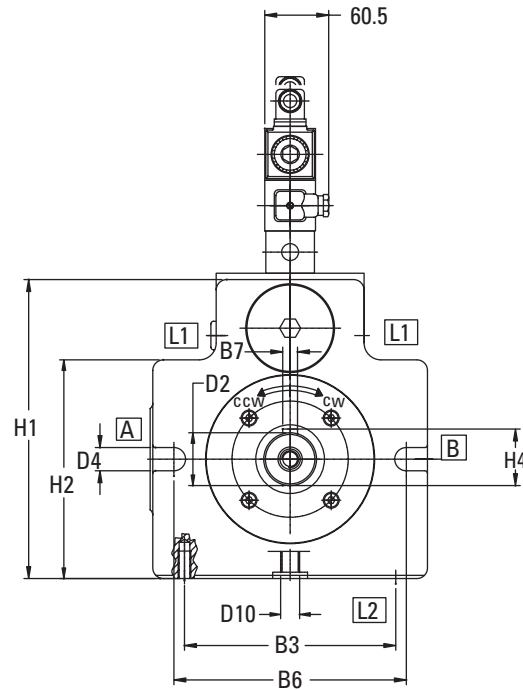

SIZE	B1	B2	B3	B4	B5	B6	B7 h9
066	210	116	160	235	120	180	10
090	210	116	160	235	120	180	10
130	260	140	200	265	120	224	14
180	260	140	200	265	120	224	14

SIZE	D1 h8	D2 k6	D3	D4	D5	D6 Light Execution	D7 DEEP	D8 DEEP	D9	D10 DEEP	D11	D12 SAEJ475
066	125	38	M12	18	M10	M22x1.5	M10 20	M12 18	25	M18x1.5 12	W40x1.25x10a	7/8-14 UNF
090	125	38	M12	18	M10	M22x1.5	M10 20	M12 20	25	M18x1.5 12	W40x1.25x10a	7/8-14 UNF
130	160	50	M16	22	M10	M26x1.5	M12 26	M12 20	25	M18x1.5 12	W50x1.25x10a	1 1/16-12 UNF
180	160	50	M16	22	M10	M26x1.5	M12 26	M14 22	30	M18x1.5 12	W50x1.25x10a	1 1/16-12 UNF

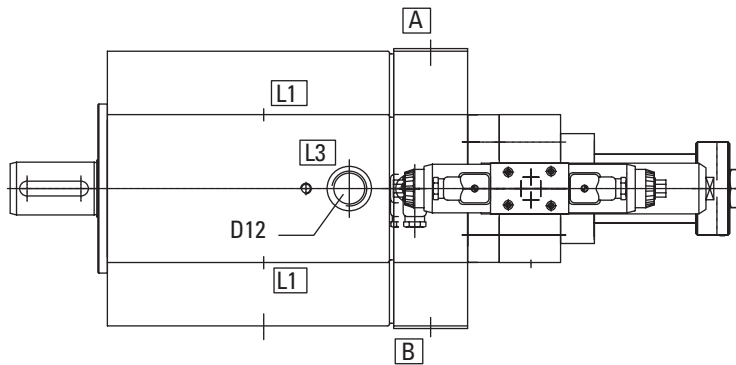
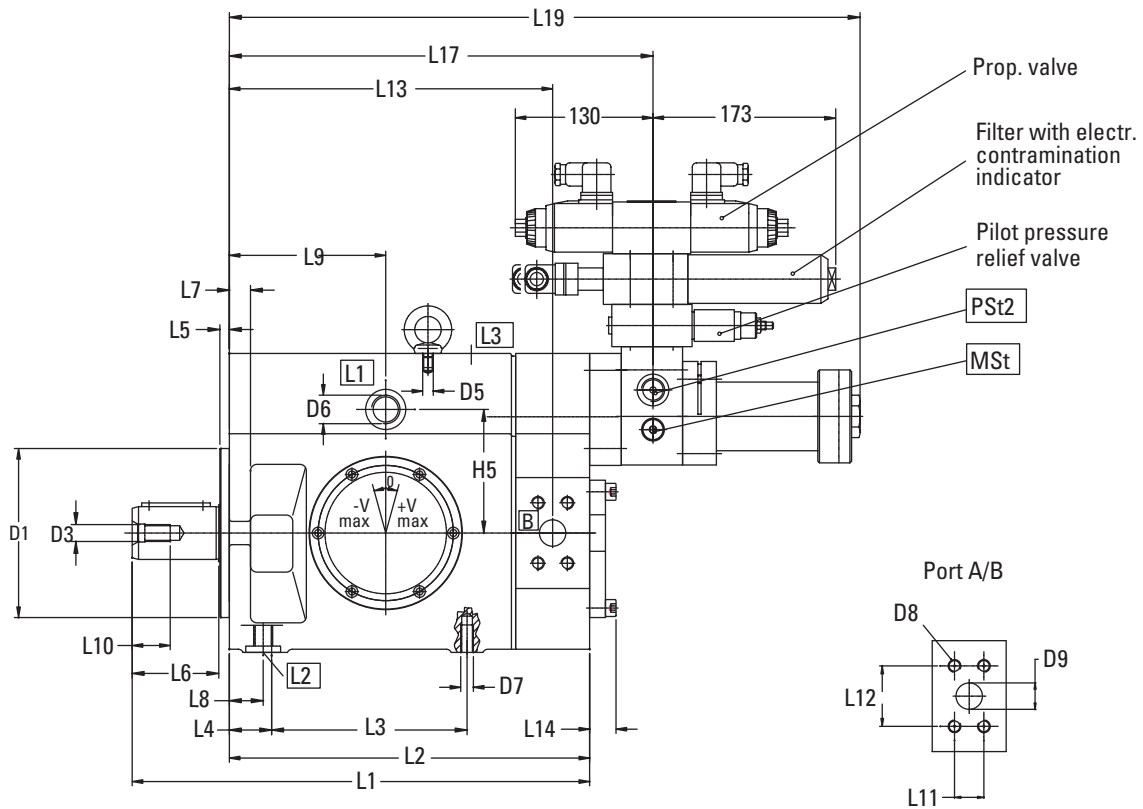

For Splined Data See Table

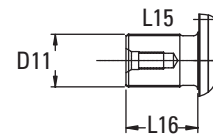

SIZE	H1	H2	H3	H4	H5	H6	H7	H8	H9
066	227	162	90	41	93	130	53	88	143
090	227	162	90	41	93	130	53	88	143
130	283	207	113	53.5	117	130	64	110	176
180	283	207	113	53.5	117	130	64	110	176

SIZE	L1	L2	L3	L4	L5	L6	L7	L8	L9	L10	L11	L12	L13	L14	L15	L16	L17	L18	L19
066	342	274	150	35	8	58	16	26	120	28	27.8	57.2	245.6	25	68	58	328	501	
090	342	274	150	35	8	58	16	26	120	28	27.8	57.2	245.6	25	68	58	328	501	
130	433	341	185	40	9	82	20	32	148	36	27.8	57.2	306	26	78	68	401	597	
180	433	341	185	40	9	82	20	32	148	36	31.8	66.7	306	26	78	68	401	597	

Installation Data

Installation position

Shaft horizontal

Highest drain port is to be used. Drain line must be arranged in such a way that motor housing is kept full at all times. If necessary, the drain line is to be looped above the motor.

Drain piping

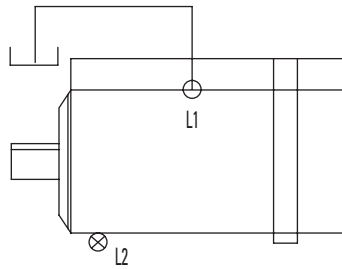

Note:

Drain piping shown, with respect to installation positions, is required for proper bearing lubrication. Also, see case flushing information next page.

Shaft down

Use venting port L3 (provided only on request). Pre-load drain port L1 with 0,2 bar (3 psi).

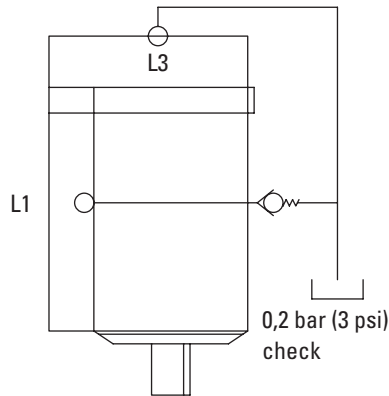

Shaft up

Use venting port L2. Pre-load drain port L1 with 0,2 bar (3 psi).

