

Group 1 Gear Pumps

Technical Information

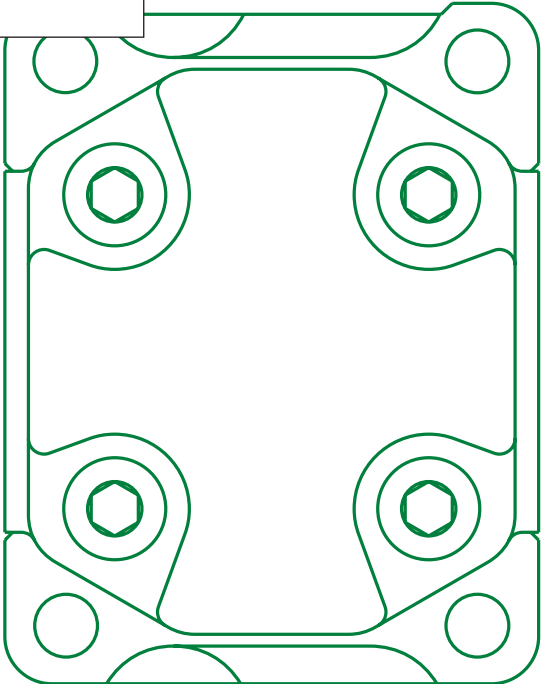
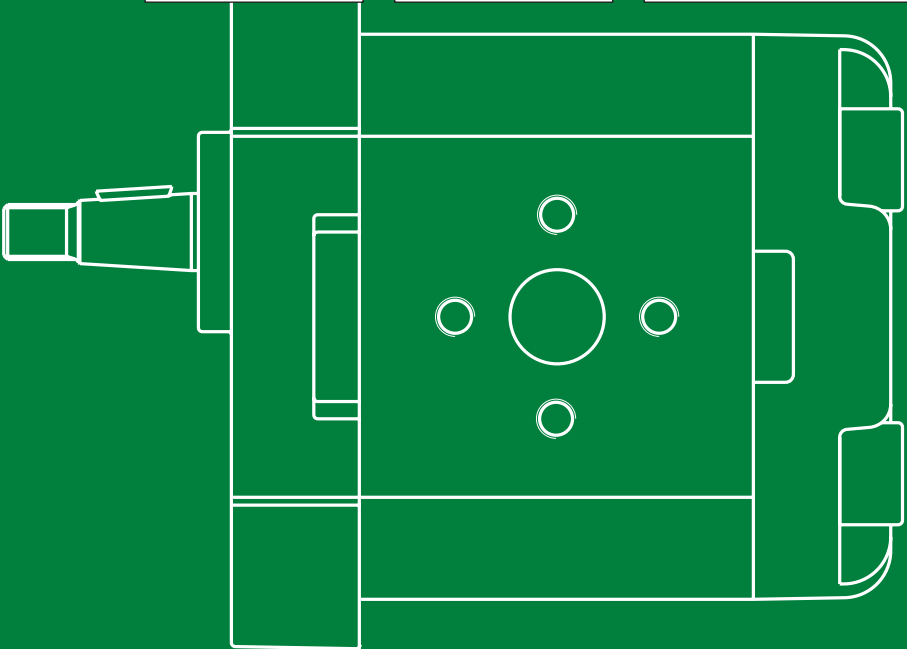
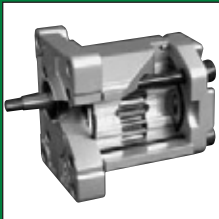
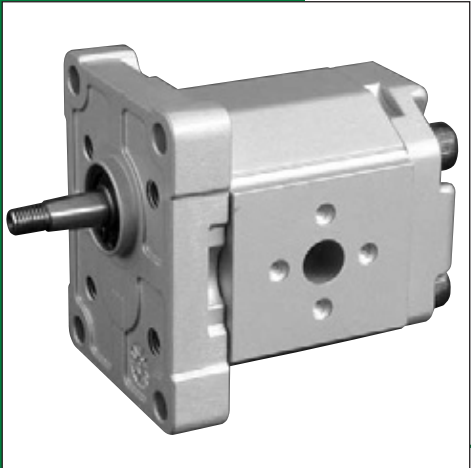
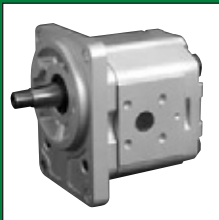
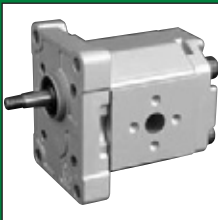

Group 1 Gear Pumps

Technical Information

General Information

History of revisions

Table of revisions

Date	Page	Changed	Rev.
24, June 2010	-	First edition	A

Reference documents

Literature reference for gear products

Title	Type	Order number
General Aluminum Gear Pumps and Motors	Technical Information	L1016238
Group 2 Gear Pumps	Technical Information	L1016341
Group 3 Gear Pumps	Technical Information	L1016456
Group 1, 2 and 3 Gear Motors	Technical Information	L1016082
Hydraulic Fluids and Lubricants	Technical Information	L1021414
Experience with Biodegradable Hydraulic Fluids	Technical Information	L1021903

Overview

The Turolla OCG Group 1 is a range of peak performance fixed-displacement gear pumps. Constructed of a high-strength extruded aluminum body with aluminum cover and flange, all pumps are pressure-balanced for exceptional efficiency. The flexibility of the range, combined with high efficiency and low noise, makes the pumps in this series ideal for a wide range of applications, including: turf care, aerial lifts, material handling, and power packs.



Features and benefits

Gear pump attributes:

- Up to 11 displacements from 1.2 to 12 cm³/rev [from 0.072 to 0.732 in³/rev]
- Continuous pressure rating up to 250 bar [3625 psi]
- Speeds up to 4000 min⁻¹ (rpm)
- SAE, ISO, and DIN mounting flanges and shafts
- Compact, lightweight, quiet operation
- Available as unidirectional and bi-directional motors, also with integral relief valve
- You can combine groups 1, 2 and 3 to make multi-stage pumps

© 2010 Turolla OpenCircuitGear™. All rights reserved.

Turolla OCG accepts no responsibility for possible errors in catalogs, brochures and other printed material. Turolla OCG reserves the right to alter its products without prior notice. This also applies to products already ordered provided that such alterations can be made without affecting agreed specifications. All trademarks in this material are properties of their respective owners. Sauer-Danfoss, Turolla, Turolla OpenCircuitGear, Turolla OCG, OpenCircuitGear, Fast Lane and PLUS+1 are trademarks of the Sauer-Danfoss Group.

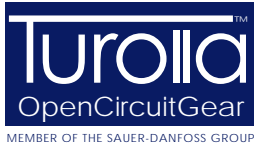

Group 1 Gear Pumps Technical Information Contents

General Information	Pump design.....	4
	Pump displacements	4
	SEP1NN	4
	SNP1NN	4
	SKP1NN.....	4
	SNP1IN.....	4
	Technical data.....	5
Product Coding	Model code.....	6
Determination of Nominal Pump Sizes	Determination of nominal pump sizes.....	8
System Requirements	Pressure.....	9
	Speed	9
	Hydraulic fluids	10
	Temperature and	10
	viscosity	10
	Filtration.....	11
	Reservoir	11
	Filters	11
	Selecting a filter.....	11
	Line sizing	12
	Pump drive	12
	Pump drive data form.....	13
	Pump life.....	14
	Sound levels	14
Pump Performance	Pump performance graphs.....	15
Product Options	Flange, shaft and port configurations	18
	Mounting flanges.....	19
	Shaft options.....	19
	Inlet/Outlet port configurations	20
	Ports	21
	Integral relief valve	22
	Integral relief valve covers SNP1IN	22
	Variant codes for ordering integral relief valves	23
	Integral relief valve schematic.....	23
Dimensions	SNP1NN – 01BA and 01DA.....	24
	SKP1NN – 02BB and 02FA.....	25
	SNP1NN, SEP1NN – 03CA	26
	SKP1NN – 06GA and 06SA.....	27

Group 1 Gear Pumps Technical Information General Information

Pump design

SEP1NN

SEP1NN is available in a limited displacement range. In addition to European flange and shaft configurations (*code 01DA, 01BA, and 03CA*), the range includes special shafts and flanges for power pack applications. SEP1NN has a lower pressure rating than SNP1NN and SKP1NN.

SNP1NN

SNP1NN is available in a limited displacement range but with higher-pressure ratings than the SEP1NN. This is because of DU bushings used in its design. SNP1NN pumps only include European flange and shaft configurations (*code 01BA, 01DA, and 03CA*).

SNP1NN 01BA (cut away)

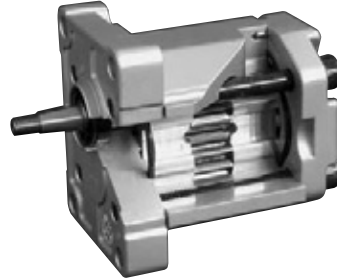

SKP1NN

SKP1NN has a larger diameter shaft than either the SEP1NN or SNP2. It spans the complete displacement range at higher pressures than the SEP1NN and SNP1NN. Configurations include European and SAE flanges and shafts (*code 02BB, 02FA, 06SA, and 06GA*).

SNP1IN

Turolia OCG offers an optional integral relief valve integrated in the rear cover. It is drained internally and directs all flow from the pump outlet to the inlet when the outlet pressure reaches the valve setting. SNI1 pumps only include European flange and shaft configurations (*code 01BA, 01DA, and 03CA*).

SNP1IN 03CA (cut away)



Pump displacements

Quick reference chart for pump displacements vs. rated pressure

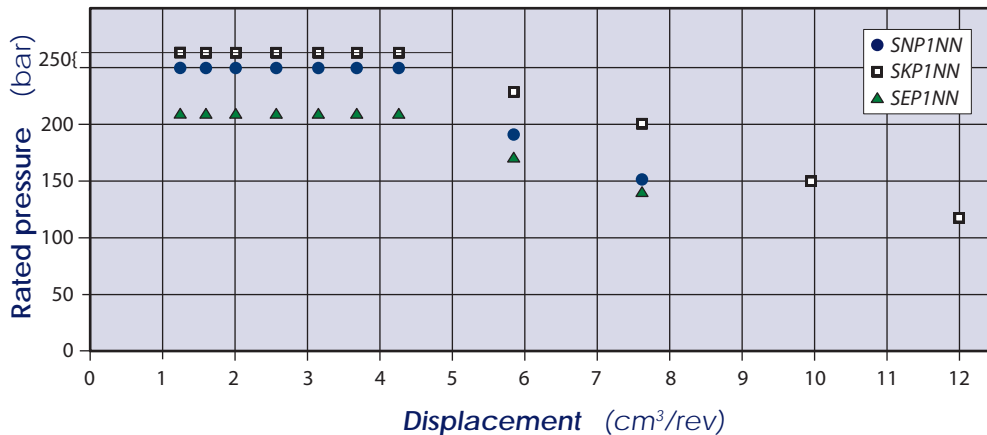

Technical data

Specifications for the SNP1NN, SEP1NN and SKP1NN Group 1 gear pumps.

		Frame size										
		1,2	1,7	2,2	2,6	3,2	3,8	4,3	6,0	7,8	010	012
Displacement	cm ³ /rev [in ³ /rev]	1.18 [0.072]	1.57 [0.096]	2.09 [0.128]	2.62 [0.160]	3.14 [0.192]	3.66 [0.223]	4.19 [0.256]	5.89 [0.359]	7.59 [0.463]	9.94 [0.607]	12.00 [0.732]
SNP1NN												
Peak pressure	bar [psi]	270 [3915]	270 [3915]	270 [3915]	270 [3915]	270 [3915]	270 [3915]	270 [3915]	210 [3045]	170 [2465]	-	-
Rated pressure		250 [3625]	250 [3625]	250 [3625]	250 [3625]	250 [3625]	250 [3625]	250 [3625]	190 [2760]	150 [2175]		
Minimum speed at 0-150 bar	min ⁻¹ (rpm)	800	800	600	600	600	600	500	500	500		
Min. speed at 150 bar to rated pressure		1200	1200	1000	1000	1000	1000	800	800	800		
Maximum speed		4000	4000	4000	4000	4000	4000	3000	3000	3000		
SEP1NN												
Peak pressure	bar [psi]	230 [3335]	230 [3335]	230 [3335]	230 [3335]	230 [3335]	230 [3335]	230 [3335]	190 [2760]	160 [2320]	-	-
Rated pressure		210 [3045]	210 [3045]	210 [3045]	210 [3045]	210 [3045]	210 [3045]	210 [3045]	170 [2465]	140 [2030]		
Minimum speed at 0-150 bar	min ⁻¹ (rpm)	800	800	600	600	600	600	500	500	500		
Min. speed at 150 bar to rated pressure		1200	1200	1000	1000	1000	1000	800	800	800		
Maximum speed		4000	4000	4000	4000	4000	4000	3000	3000	3000		
SKP1NN*												
Peak pressure	bar [psi]	270 [3915]	270 [3915]	270 [3915]	270 [3915]	270 [3915]	270 [3915]	270 [3915]	250 [3625]	220 [3190]	170 [2465]	140 [2030]
Rated pressure		250 [3625]	250 [3625]	250 [3625]	250 [3625]	250 [3625]	250 [3625]	250 [3625]	230 [3335]	200 [2900]	150 [2175]	120 [1740]
Minimum speed at 0-150 bar	min ⁻¹ (rpm)	800	800	800	800	800	800	600	600	600	600	600
Min. speed at 150 bar to rated pressure		1200	1200	1000	1000	1000	1000	1000	800	800	800	-
Maximum speed		4000	4000	4000	4000	4000	4000	3000	3000	3000	2000	2000
All (SNP1NN, SEP1NN, SKP1NN)												
Weight	kg [lb]	1.02 [2.26]	1.05 [2.31]	1.09 [2.40]	1.11 [2.45]	1.14 [2.51]	1.18 [2.60]	1.20 [2.65]	1.30 [2.87]	1.39 [3.06]	1.55 [3.42]	1.65 [3.64]
Moment of inertia of rotating components	x 10 ⁻⁶ kg·m ² [x 10 ⁻⁶ lb·ft ²]	3.2 [77]	3.7 [89]	4.4 [105]	5.1 [120]	5.7 [136]	6.4 [152]	7.1 [168]	9.3 [220]	11.4 [271]	14.6 [347]	17.1 [407]
Theoretical flow at maximum speed	l/min [US gal/min]	4.72 [1.25]	6.28 [1.66]	8.36 [2.21]	10.48 [2.77]	12.56 [3.32]	14.64 [3.87]	12.57 [3.32]	17.67 [4.67]	22.77 [6.02]	19.88 [5.25]	24 [6.34]

1 kg·m² = 23.68 lb·ft²

* SKP1NN is a special version of the SNP1NN. It is designed to accommodate an SAE 9T 20/40 DP tooth splined shaft for higher torque applications.

⚠ Caution

The rated and peak pressure mentioned are for pumps with flanged ports only. When threaded ports are required a de-rated performance has to be considered. To verify the compliance of an high pressure application with a threaded ports pump apply to a Turola OCG representative.

Group 1 Gear Pumps

Technical Information

Product Coding

Model code

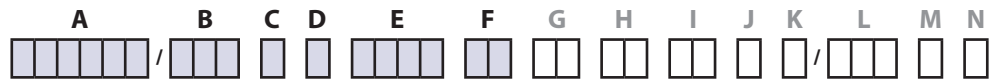

A Type

SEP1NN	Medium pressure gear pump
SNP1NN	Standard gear pump
SKP1NN	High torque gear pump
SNP1IN	Standard gear pump, integrated RV
SKP1IN	High torque gear pump, integrated RV

B Displacement

1,2	1.18 cm ³ /rev [0.072 in ³ /rev]
1,7	1.57 cm ³ /rev [0.096 in ³ /rev]
2,2	2.09 cm ³ /rev [0.128 in ³ /rev]
2,6	2.62 cm ³ /rev [0.160 in ³ /rev]
3,2	3.14 cm ³ /rev [0.192 in ³ /rev]
3,8	3.66 cm ³ /rev [0.223 in ³ /rev]
4,3	4.19 cm ³ /rev [0.256 in ³ /rev]
6,0	5.89 cm ³ /rev [0.359 in ³ /rev]
7,8	7.59 cm ³ /rev [0.463 in ³ /rev]
010	9.40 cm ³ /rev [0.607 in ³ /rev]
012	12.0 cm ³ /rev [0.732 in ³ /rev]

C Sense of rotation

R	Right (Clockwise)
L	Left (Counterclockwise)

D Version

N	Standard gear pump
----------	--------------------

E Mounting flange/drive gear

Code	Description (Type of flange • type of drive gear • preferred ports for configuration)	SNP1NN	SKP1NN	SEP1NN	SNP1IN
01BA	European four bolt flange • Tapered 1:8 shaft • European flanged ports	●	●	-	●
01DA	European four bolt flange • Splined 15T 12x10 shaft • European flanged ports	●	-	-	●
02BB	European four bolts flange • Tapered 1:8 shaft • European flanged ports	-	●	-	-
02FA	European four bolts flange • Parallel shaft • European flanged ports	-	●	-	-
03CA	German two bolts PTO flange • SD Tang shaft • Metrical threaded ports	●	-	●	●
06GA	SAE A-A flange • Parallel shaft • SAE O-Ring boss ports	-	●	-	-
06SA	SAE A-A flange • SAE spline shaft • SAE O-Ring boss ports	-	●	-	-

Legend:

- Standard
- Optional
- Not Available

F Rear cover

P1	Standard cover for pump
03	Cover for 03 flange
I1	Cover for pump with relief valve
I3	Cover for 03 flange with relief valve

Group 1 Gear Pumps

Technical Information

Product Coding

Model code (continued)



G Inlet port/H Outlet port*

B1	8x30xM6	Flanged port with threaded holes in X pattern, in center of body
B2	13x30xM6	
C1	8x26xM5	Flanged port with threaded holes in + pattern (European standard ports)
C2	12x26xM5	
C3	13,5x30xM6	
D3	M14x1,5	Threaded metric port
D5	M18x1,5	
D7	M22x1,5	
E3	1/16-18UNF	Threaded SAE, O-Ring boss port
E4	3/4 -16UNF	
E5	7/8-14UNF	
F2	1/4 GAS	Threaded GAS (BSPP) port
F3	3/8 GAS	
F4	1/2 GAS	
H5	M18x1,5	Threaded metric port ISO 6149
H7	M22x1,5	

* For the information see *Port dimensions*, page 21.

I Port position and variant body

NN	Standard gear pump from catalogue
-----------	-----------------------------------

J Sealing

N	Standard Buna seal
A	Without shaft seal
B	VITON seals

K Screws

N	Standard screws
A	Galvanized screws+nuts-washers
B	DACROMET/GEOMET screws

L Set valve

NNN	No valve
V**	Integral RV-Pressure setting. Pump speed for relief valve setting (min ⁻¹ [rpm])

M Marking

N	Standard marking
A	Standard marking + Customer Code
Z	Without marking

N Mark position

N	Standard marking position
A	Mark on the bottom ref. to drive gear

Group 1 Gear Pumps Technical Information Determination of Nominal Pump Sizes

Determination of nominal pump sizes

Use these formulae to determine the nominal pump size for a specific application:

Based on SI units

$$\text{Output flow: } Q = \frac{V_g \cdot n \cdot \eta_v}{1000} \quad \text{l/min}$$

$$\text{Input torque: } M = \frac{V_g \cdot \Delta p}{20 \cdot \pi \cdot \eta_m} \quad \text{N}\cdot\text{m}$$

$$\text{Input power: } P = \frac{M \cdot n}{9550} = \frac{Q \cdot \Delta p}{600 \cdot \eta_t} \quad \text{kW}$$

Based on US units

$$Q = \frac{V_g \cdot n \cdot \eta_v}{231} \quad \text{[US gal/min]}$$

$$M = \frac{V_g \cdot \Delta p}{2 \cdot \pi \cdot \eta_m} \quad \text{[lbf}\cdot\text{in]}$$

$$P = \frac{M \cdot n}{63.025} = \frac{Q \cdot \Delta p}{1714 \cdot \eta_t} \quad \text{[hp]}$$

Variables: SI units [US units]

V_g	= Displacement per rev.	cm^3/rev [in^3/rev]
p_{HD}	= Outlet pressure	bar [psi]
p_{ND}	= Inlet pressure	bar [psi]
Δp	= $p_{\text{HD}} - p_{\text{ND}}$	bar [psi]
n	= Speed	min^{-1} (rpm)
η_v	= Volumetric efficiency	
η_m	= Mechanical (torque) efficiency	
η_t	= Overall efficiency ($\eta_v \cdot \eta_m$)	

Group 1 Gear Pumps Technical Information System Requirements

Pressure

The inlet vacuum must be controlled in order to realize expected pump life and performance. The system design must meet inlet pressure requirements during all modes of operation. Expect lower inlet pressures during cold start. It should improve quickly as the fluid warms.

Inlet pressure

Maximum continuous vacuum	bar absolute [in. Hg]	0.8 [23.6]
Maximum intermittent vacuum		0.6 [17.7]
Maximum pressure		3.0 [88.5]

Peak pressure is the highest intermittent pressure allowed. The relief valve overshoot (reaction time) determines peak pressure. It is assumed to occur for less than 100 ms. The illustration to the right shows peak pressure in relation to rated pressure and reaction time (100 ms maximum).

Rated pressure is the average, regularly occurring, operating pressure that should yield satisfactory product life. The maximum machine load demand determines rated pressure. For all systems, the load should move below this pressure.

System pressure is the differential between the outlet and inlet ports. It is a dominant operating variable affecting hydraulic unit life. High system pressure, resulting from high load, reduces expected life. System pressure must remain at, or below, rated pressure during normal operation to achieve expected life.

Time versus pressure

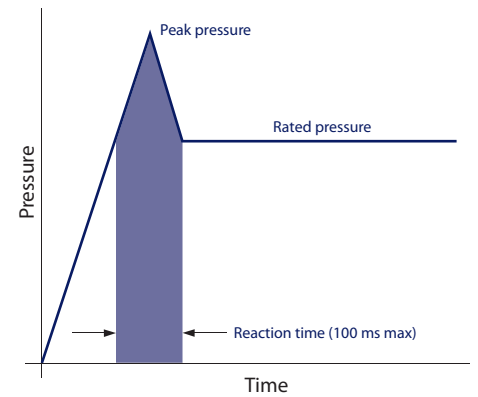

Speed

Maximum speed is the limit recommended by Turola OCG for a particular gear pump when operating at rated pressure. It is the highest speed at which normal life can be expected.

The lower limit of operating speed is the **minimum speed**. It is the lowest speed at which normal life can be expected. The minimum speed increases as operating pressure increases. When operating under higher pressures, a higher minimum speed must be maintained, as illustrated to the right.

Speed versus pressure

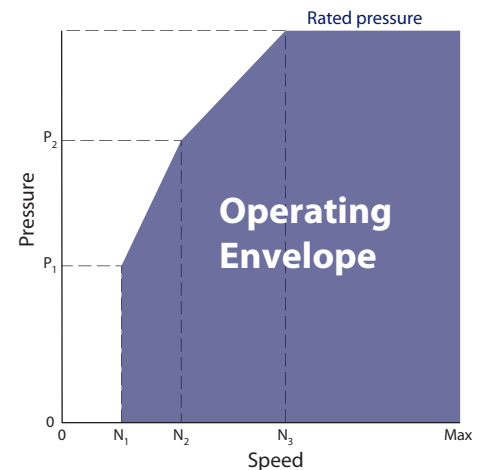

Where:
N₁ = Minimum speed at 100 bar
N₂ = Minimum speed at 180 bar
N₃ = Minimum speed at rated pressure

Group 1 Gear Pumps Technical Information System Requirements

Hydraulic fluids

Ratings and data for SNP1NN, SEP1NN and SKP1NN gear pumps are based on operating with premium hydraulic fluids containing oxidation, rust, and foam inhibitors. These fluids must possess good thermal and hydrolytic stability to prevent wear, erosion, and corrosion of internal components. They include:

- Hydraulic fluids following DIN 51524, part 2 (HLP) and part 3 (HVLP) specifications
- API CD engine oils conforming to SAE J183
- M2C33F or G automatic transmission fluids
- Certain agricultural tractor fluids

Use only clean fluid in the pump and hydraulic circuit.

⚠ Caution

Never mix hydraulic fluids.

Please see Turolla OCG publication *Hydraulic Fluids and Lubricants Technical Information*, **L1021414** for more information. Refer to publication *Experience with Biodegradable Hydraulic Fluids Technical Information*, **L1021903** for information relating to biodegradable fluids.

Temperature and viscosity

Temperature and viscosity requirements must be concurrently satisfied. Use petroleum / mineral-based fluids.

High temperature limits apply at the inlet port to the pump. The pump should run at or below the maximum continuous temperature. The peak temperature is based on material properties. Don't exceed it.

Cold oil, generally, doesn't affect the durability of pump components. It may affect the ability of oil to flow and transmit power. For this reason, keep the temperature at 16 °C [60 °F] above the pour point of the hydraulic fluid.

Minimum (cold start) temperature relates to the physical properties of component materials.

Minimum viscosity occurs only during brief occasions of maximum ambient temperature and severe duty cycle operation. You will encounter maximum viscosity only at cold start. During this condition, limit speeds until the system warms up. Size heat exchangers to keep the fluid within these limits. Test regularly to verify that these temperatures and viscosity limits aren't exceeded. For maximum unit efficiency and bearing life, keep the fluid viscosity in the recommended viscosity range.

Fluid viscosity

Maximum (cold start)	mm ² /s [SUS]	1000 [4600]
Recommended range		12-60 [66-290]
Minimum		10 [60]

Temperature

Minimum (cold start)	°C [°F]	-20 [-4]
Maximum continuous		80 [176]
Peak (intermittent)		90 [194]

Filtration

Filters

Use a filter that conforms to Class 22/18/13 of ISO 4406 (or better). It may be on the pump outlet (pressure filtration), inlet (suction filtration), or reservoir return (return-line filtration).

Selecting a filter

When selecting a filter, please consider:

- contaminant ingress rate (determined by factors such as the number of actuators used in the system)
- generation of contaminants in the system
- required fluid cleanliness
- desired maintenance interval
- filtration requirements of other system components

Measure filter efficiency with a Beta ratio (β_x). For:

- suction filtration, with controlled reservoir ingress, use a $\beta_{35-45} = 75$ filter
- return or pressure filtration, use a pressure filtration with an efficiency of $\beta_{10} = 75$.

β_x ratio is a measure of filter efficiency defined by ISO 4572. It is the ratio of the number of particles greater than a given diameter (" x " in microns) upstream of the filter to the number of these particles downstream of the filter.

Fluid cleanliness level and β_x ratio

Fluid cleanliness level (per ISO 4406)	Class 22/18/13 or better
β_x ratio (suction filtration)	$\beta_{35-45} = 75$ and $\beta_{10} = 2$
β_x ratio (pressure or return filtration)	$\beta_{10} = 75$
Recommended inlet screen size	100-125 μm [0.004-0.005 in]

The filtration requirements for each system are unique. Evaluate filtration system capacity by monitoring and testing prototypes.

Reservoir

The **reservoir** provides clean fluid, dissipates heat, removes entrained air, and allows for fluid volume changes associated with fluid expansion and cylinder differential volumes. A correctly sized reservoir accommodates maximum volume changes during all system operating modes. It promotes deaeration of the fluid as it passes through, and accommodates a fluid dwell-time between 60 and 180 seconds, allowing entrained air to escape.

Minimum reservoir capacity depends on the volume required to cool and hold the oil from all retracted cylinders, allowing for expansion due to temperature changes. A fluid volume of 1 to 3 times the pump output flow (per minute) is satisfactory. The minimum reservoir capacity is 125% of the fluid volume.

Install the suction line above the bottom of the reservoir to take advantage of gravity separation and prevent large foreign particles from entering the line. Cover the line with a 100-125 micron screen. The pump should be below the lowest expected fluid level.

Put the return-line below the lowest expected fluid level to allow discharge into the reservoir for maximum dwell and efficient deaeration. A baffle (or baffles) between the return and suction lines promotes deaeration and reduces fluid surges.

Group 1 Gear Pumps Technical Information System Requirements

Line sizing

Choose pipe sizes that accommodate minimum fluid velocity to reduce system noise, pressure drops, and overheating. This maximizes system life and performance. Design inlet piping that maintains continuous pump inlet pressure above 0.8 bar absolute during normal operation. The line velocity should not exceed the values in this table:

Maximum line velocity

Inlet		2.5 [8.2]
Outlet	m/s [ft/sec]	5.0 [16.4]
Return		3.0 [9.8]

Most systems use hydraulic oil containing 10% dissolved air by volume. Under high inlet vacuum conditions the oil releases bubbles. They collapse when subjected to pressure, resulting in cavitation, causing adjacent metal surfaces to erode. **Over-aeration** is the result of air leaks on the inlet side of the pump, and flow-line restrictions. These include inadequate pipe sizes, sharp bends, or elbow fittings, causing a reduction of flow line cross sectional area. This problem will not occur if inlet vacuum and rated speed requirements are maintained, and reservoir size and location are adequate.

Pump drive

Shaft options for Group 1 gear pumps include tapered, tang, splined, or parallel shafts. They are suitable for a wide range of direct and indirect drive applications for radial and thrust loads.

Plug-in drives, acceptable only with a splined shaft, can impose severe radial loads when the mating spline is rigidly supported. Increasing spline clearance does not alleviate this condition.

Use plug-in drives if the concentricity between the mating spline and pilot diameter is within 0.1 mm [0.004 in]. Lubricate the drive by flooding it with oil. A 3-piece coupling minimizes radial or thrust shaft loads.

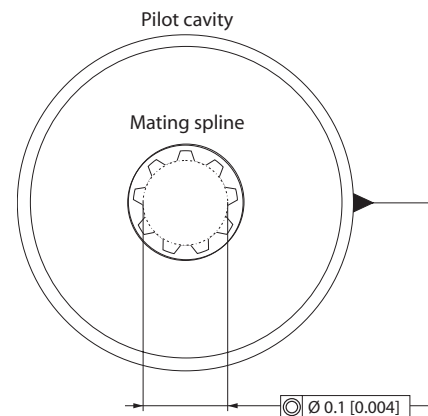

⚠ Caution

In order to avoid spline shaft damages it is recommended to use carburised and hardened steel couplings with 80-82 HRA surface hardness.

Allowable **radial shaft loads** are a function of the load position, load orientation, and operating pressure of the hydraulic pump. All external shaft loads have an effect on bearing life, and may affect pump performance.

In applications where external shaft loads can't be avoided, minimize the impact on the pump by optimizing the orientation and magnitude of the load. Use a tapered input shaft; don't use splined shafts for belt or gear drive applications. A spring-loaded belt tension-device is recommended for belt drive applications to avoid excessive tension. Avoid thrust loads in either direction. Contact Turolla OCG if continuously applied external radial or thrust loads occur.

Group 1 Gear Pumps Technical Information System Requirements

Pump drive data form

Photocopy this page and fax the complete form to your Turolld OCG representative for an assistance in applying pumps with belt or gear drive. This illustration shows a pump with counterclockwise orientation:

Optimal radial load position

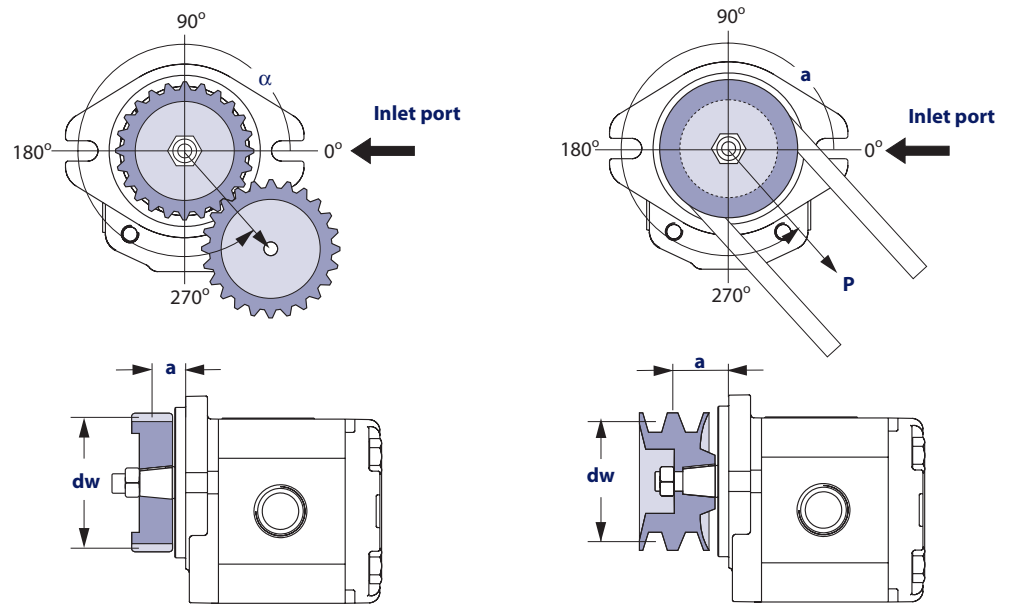

Application data

Item	Value	Unit
Pump displacement		cm ³ /rev [in ³ /rev]
Rated system pressure		<input type="checkbox"/> bar <input type="checkbox"/> psi
Relief valve setting		
Pump shaft rotation		<input type="checkbox"/> left <input type="checkbox"/> right
Pump minimum speed		
Pump maximum speed		min ⁻¹ (rpm)
Drive gear helix angle (gear drive only)		degree
Belt type (gear drive only)		<input type="checkbox"/> V <input type="checkbox"/> notch
Belt tension (gear drive only)	P	<input type="checkbox"/> N <input type="checkbox"/> lbf
Angular orientation of gear or belt to inlet port	α	degree
Pitch diameter of gear or pulley	d_w	<input type="checkbox"/> mm <input type="checkbox"/> in
Distance from flange to center of gear or pulley	a	

Group 1 Gear Pumps Technical Information System Requirements

Pump life

Pump life is a function of speed, system pressure, and other system parameters (such as fluid quality and cleanliness).

All Turolla OCG gear pumps use hydrodynamic journal bearings that have an oil film maintained between the gear/shaft and bearing surfaces at all times. If the oil film is sufficiently sustained through proper system maintenance and operating within recommended limits, long life can be expected.

B_{10} life expectancy number is generally associated with rolling element bearings. It does not exist for hydrodynamic bearings.

High pressure, resulting from high loads, impacts pump life. When submitting an application for review, provide machine duty cycle data that includes percentages of time at various loads and speeds. We strongly recommend a prototype testing program to verify operating parameters and their impact on life expectancy before finalizing any system design.

Sound levels

Noise is unwanted sound. Fluid power systems create noise. There are many techniques available to minimize noise. Understanding how it's generated and transmitted is necessary to apply these methods effectively.

Noise energy is transmitted as fluid borne noise (pressure ripple) or structure borne noise. **Pressure ripple** is the result of the number of pumping elements (gear teeth) delivering oil to the outlet and the pump's ability to gradually change the volume of each pumping element from low to high pressure. Pressure ripple is affected by the compressibility of the oil as each pumping element discharges into the outlet of the pump. Pressure pulsations travel along hydraulic lines at the speed of sound (about 1400 m/s in oil) until there is a change in the system (as with an elbow fitting). Thus, the pressure pulsation amplitude varies with overall line length and position.

Structure borne noise may be transmitted wherever the pump casing is connected to the rest of the system.

The way circuit components respond to excitation depends on their size, form, and mounting. Because of this, a system line may actually have a greater noise level than the pump. To minimize noise, use:

- flexible hoses (if you must use steel plumbing, clamp the lines).
- flexible (rubber) mounts to minimize other structure borne noise.

Pump performance graphs

The graphs on the next few pages provide typical output flow and input power for Group 1 pumps at various working pressures. Data were taken using ISO VG46 petroleum / mineral based fluid at 50°C (viscosity at 28 mm²/s [cSt]).

Performance graph for 1.2 frame size

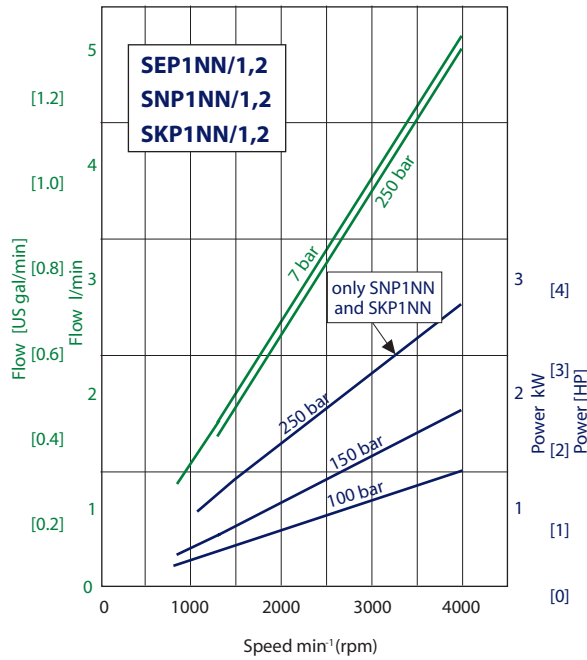

Performance graph for 1.7 frame size

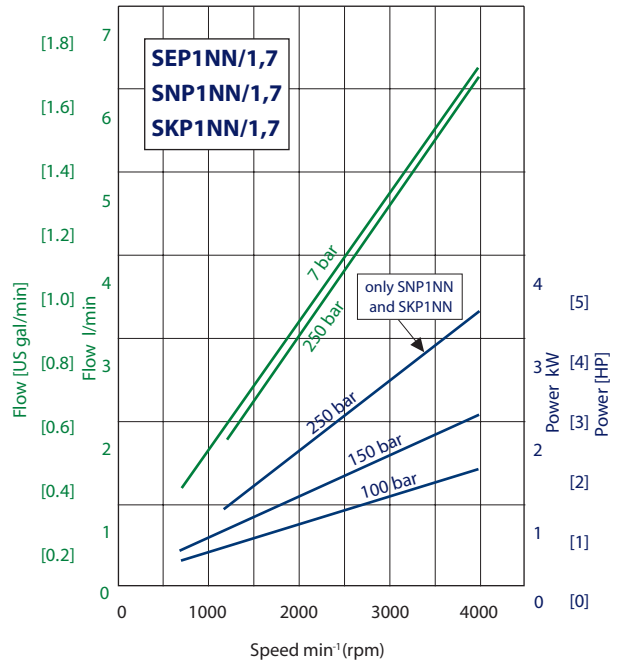

Performance graph for 2.2 frame size

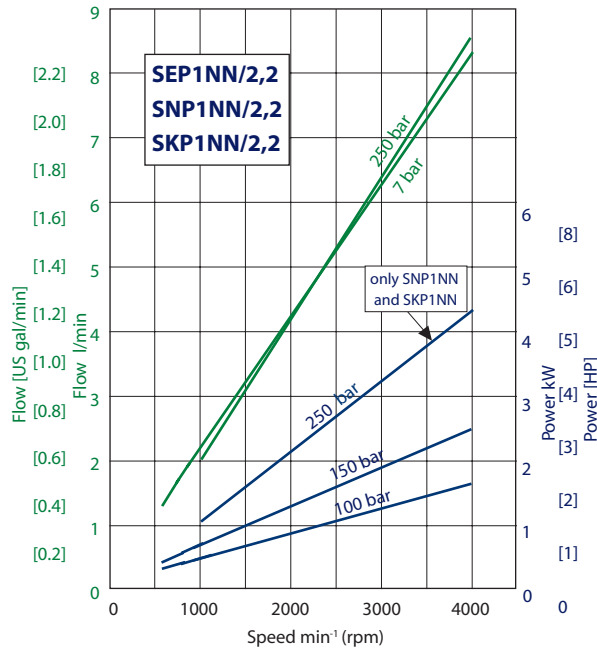

Performance graph for 2.6 frame size

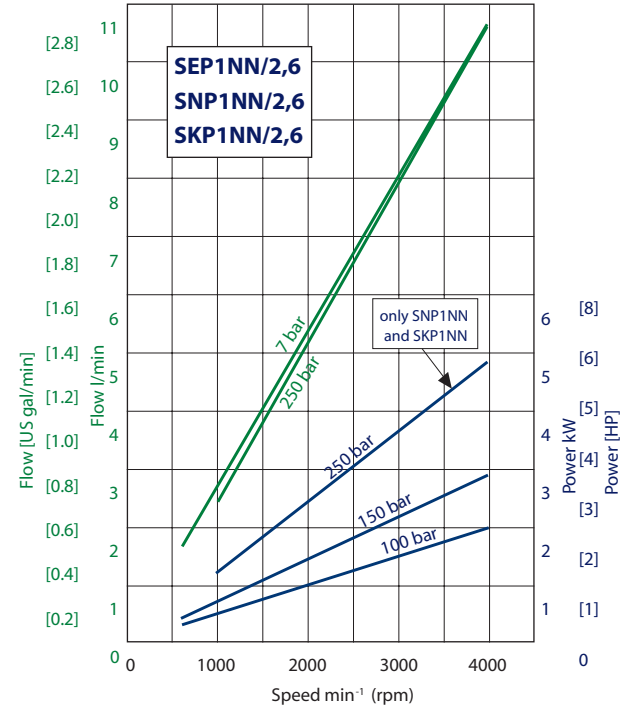

Pump performance graphs (continued)

Performance graph for 3.2 frame size

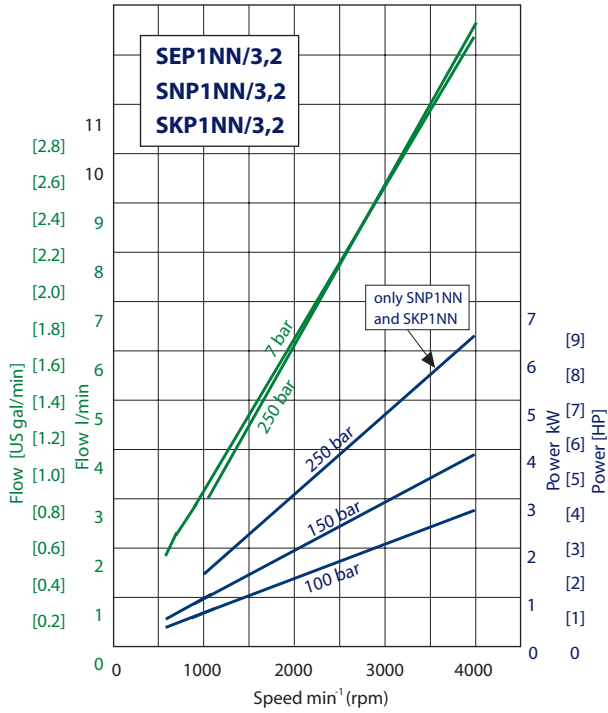

Performance graph for 3.8 frame size

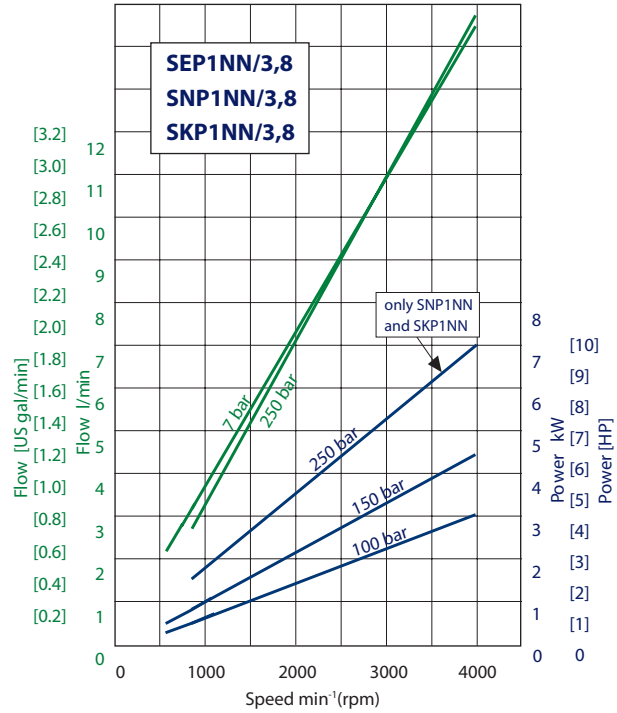

Performance graph for 4.3 frame size

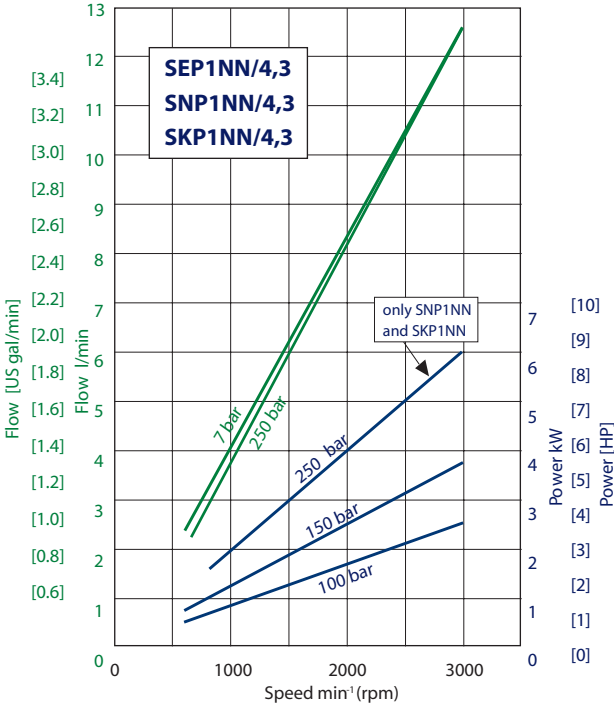

Performance graph for 6.0 frame size

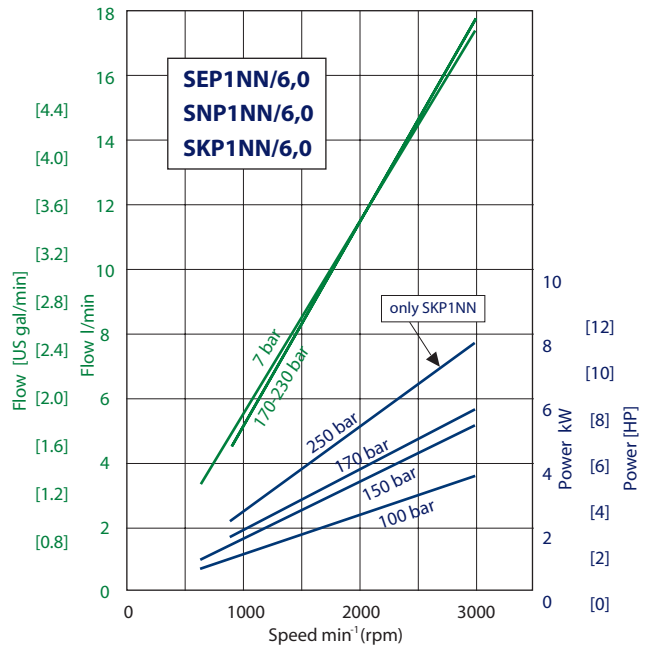

Pump performance graphs (continued)

Performance graph for 7.8 frame size

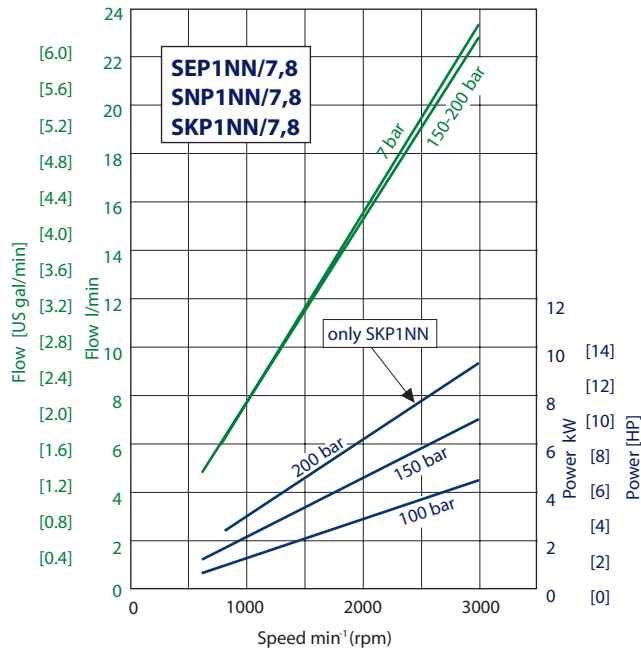

SKP1NN/010 pump performance graph

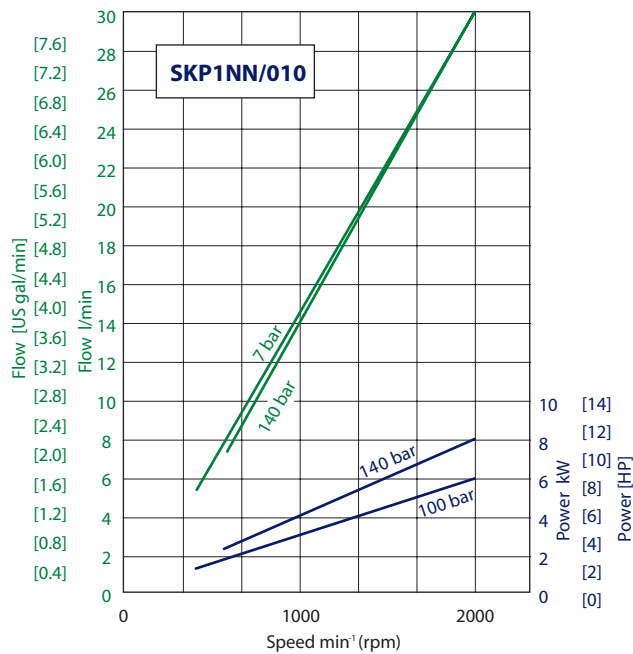

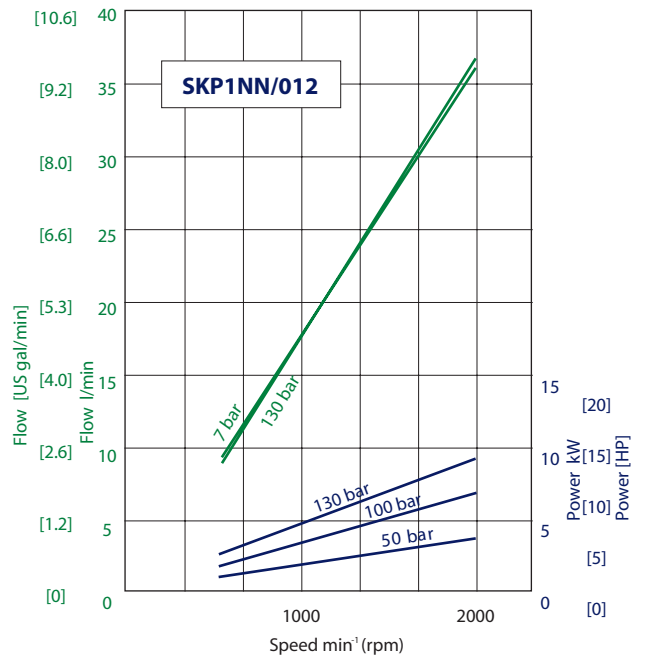

SKP1NN/012 pump performance graph





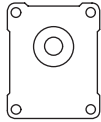
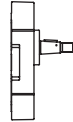
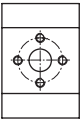
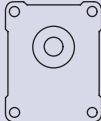
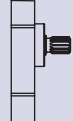
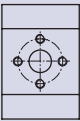

Group 1 Gear Pumps Technical Information Product Options

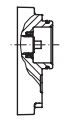
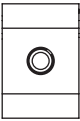
Flange, shaft and port configurations

Flange, shaft and port configurations for SEP1NN and SNP1NN

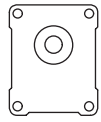
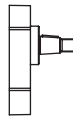
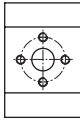
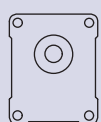
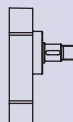
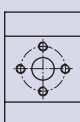
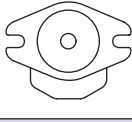
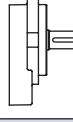
Code	Flange	Shaft	Port
01BA	25.4 mm [1.0 in] pilot Ø European 4-bolt 	1:8 tapered 	European flanged in + pattern 
01DA	25.4 mm [1.0 in] pilot Ø European 4-bolt 	15-teeth splined $m = 0.75$ $\alpha = 30^\circ$ 	European flanged in + pattern 
03CA	Turolia OCG tang 	Turolia OCG tang 	Threaded metric port 

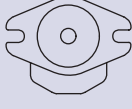
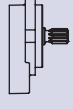
Flange, shaft and port configurations for SKP1NN

Code	Flange	Shaft	Port
02BB	30 mm [1.181] pilot Ø European 4-bolt 	1:8 tapered 	European flanged in + pattern 
02FA	30 mm [1.181] pilot Ø European 4-bolt 	12 mm [0.472 in] parallel 	European flanged in + pattern 
06GA	SAE A-A 2-bolt 	12.7 mm [0.5 in] parallel 	Threaded SAE O-Ring boss 
06SA	SAE A-A 2-bolt 	9-teeth splined SAE spline J 498- 9T-20/40DP 	Threaded SAE O-Ring boss 

Mounting flanges

Turolla OCG offers many types of industry standard mounting flanges. This table shows order codes for each available mounting flange and its intended use:

Flange availability



Flange	
Code	Description
01	European 25.4 mm 4-bolt
02	European 30 mm 4-bolt
03	Turolla OCG standard Tang drive
06	SAE A-A

Shaft options

Direction is viewed facing the shaft. Group 1 pumps are available with a variety of tang, splined, parallel, and tapered shaft ends. Not all shaft styles are available with all flange styles.

Shaft availability and nominal torque capability



Code	Shaft Description	Mounting flange code with maximum torque in Nm [lb·in]			
		01	02	03	06
BA	Taper 1:8	25 [221]	–	–	–
BB	Taper 1:8	–	50 [442]	–	–
DA	Spline T-15, m=0.75, alfa=30°	35 [310]	–	–	–
SA	SAE spline J 498-9T-20/40DP	–	–	–	34 [301]
FA	Parallel 12 mm [0.47 in]	–	24 [212]	–	–
GA	Parallel 12.7 mm [0.50 in]	–	–	–	32 [283]
CA	Turolla OCG Tang	–	–	14 [124]	–

Turolla OCG recommends mating splines conform to SAE J498 or DIN 5482. Turolla OCG external SAE splines have a flat root side fit with circular tooth thickness reduced by 0.127 mm [0.005 in] in respect to class 1 fit. Dimensions are modified to assure a clearance fit with the mating spline.

⚠ Caution

Shaft torque capability may limit allowable pressure. Torque ratings assume no external radial loading. Applied torque must not exceed these limits, regardless of stated pressure parameters. Maximum torque ratings are based on shaft torsional fatigue strength.

Group 1 Gear Pumps Technical Information Product Options

Inlet/Outlet port configurations

Various port configurations are available on Group 1 pumps. They include:

- European standard flanged ports
- German standard flanged ports
- Gas threaded ports (BSPP)
- O-Ring boss (following SAE J1926/1 [ISO 11926-1] UNF threads, standard)

A table of dimensions is on the next page.

G – Inlet port configuration codes and **H** – Outlet port configuration codes



B1	8x30xM6	Flanged port with threaded holes in X pattern, in center of body
B2	13x30xM6	
C1	8x26xM5	Flanged port with threaded holes in + pattern (European standard ports)
C2	12x26xM5	
C3	13,5x30xM6	
D3	M14x1,5	Threaded metric port
D5	M18x1,5	
D7	M22x1,5	
E3	9/16-18UNF	Threaded SAE, O-Ring boss port
E4	3/4 -16UNF	
E5	7/8-14UNF	
F2	1/4 GAS	Threaded GAS (BSPP) port
F3	3/8 GAS	
F4	1/2 GAS	
H5	M18x1,5	Threaded metric port ISO 6149
H7	M22x1,5	

Ports

Available ports

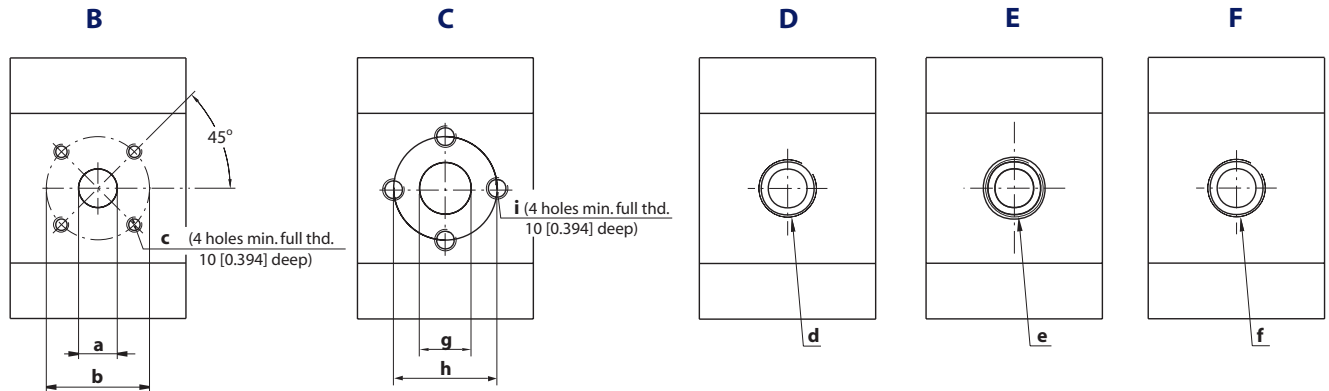

Dimensions of Group 1 pump ports

Port type		B			C			D	E	F	
Port dimension		a	b	c	g	h	i	d	e	f	
Type (displacement)	1,2	Inlet	13 [0.512]	30 [1.181]	M6	12 [0.462]	26 [1.024]	M5	M18x1.5	3/4-16UNF-2B	3/8 Gas (BSPP)
		Outlet	8 [0.315]	30 [1.181]	M6	12 [0.462]	26 [1.024]	M5	M14x1.5	9/16-18UNF-2B	3/8 Gas (BSPP)
	1,7	Inlet	13 [0.512]	30 [1.181]	M6	12 [0.462]	26 [1.024]	M5	M18x1.5	3/4-16UNF-2B	3/8 Gas (BSPP)
		Outlet	8 [0.315]	30 [1.181]	M6	12 [0.462]	26 [1.024]	M5	M14x1.5	9/16-18UNF-2B	3/8 Gas (BSPP)
	2,2	Inlet	13 [0.512]	30 [1.181]	M6	12 [0.462]	26 [1.024]	M5	M18x1.5	3/4-16UNF-2B	3/8 Gas (BSPP)
		Outlet	8 [0.315]	30 [1.181]	M6	12 [0.462]	26 [1.024]	M5	M14x1.5	9/16-18UNF-2B	3/8 Gas (BSPP)
	2,6	Inlet	13 [0.512]	30 [1.181]	M6	12 [0.462]	26 [1.024]	M5	M18x1.5	3/4-16UNF-2B	3/8 Gas (BSPP)
		Outlet	8 [0.315]	30 [1.181]	M6	12 [0.462]	26 [1.024]	M5	M14x1.5	9/16-18UNF-2B	3/8 Gas (BSPP)
	3,2	Inlet	13 [0.512]	30 [1.181]	M6	12 [0.462]	26 [1.024]	M5	M18x1.5	3/4-16UNF-2B	3/8 Gas (BSPP)
		Outlet	8 [0.315]	30 [1.181]	M6	12 [0.462]	26 [1.024]	M5	M14x1.5	9/16-18UNF-2B	3/8 Gas (BSPP)
	3,8	Inlet	13 [0.512]	30 [1.181]	M6	12 [0.462]	26 [1.024]	M5	M18x1.5	3/4-16UNF-2B	3/8 Gas (BSPP)
		Outlet	8 [0.315]	30 [1.181]	M6	12 [0.462]	26 [1.024]	M5	M18x1.5	9/16-18UNF-2B	3/8 Gas (BSPP)
	4,3	Inlet	13 [0.512]	30 [1.181]	M6	12 [0.462]	26 [1.024]	M5	M18x1.5	3/4-16UNF-2B	3/8 Gas (BSPP)
		Outlet	8 [0.315]	30 [1.181]	M6	12 [0.462]	26 [1.024]	M5	M18x1.5	9/16-18UNF-2B	3/8 Gas (BSPP)
	6,0	Inlet	13 [0.512]	30 [1.181]	M6	12 [0.462]	26 [1.024]	M5	M18x1.5	3/4-16UNF-2B	3/8 Gas (BSPP)
		Outlet	13 [0.512]	30 [1.181]	M6	12 [0.462]	26 [1.024]	M5	M18x1.5	9/16-18UNF-2B	3/8 Gas (BSPP)
	7,8	Inlet	13 [0.512]	30 [1.181]	M6	12 [0.462]	26 [1.024]	M5	M18x1.5	3/4-16UNF-2B	3/8 Gas (BSPP)
		Outlet	13 [0.512]	30 [1.181]	M6	12 [0.462]	26 [1.024]	M5	M18x1.5	9/16-18UNF-2B	3/8 Gas (BSPP)
	010	Inlet	13 [0.512]	30 [1.181]	M6	12 [0.462]	26 [1.024]	M5	M18x1.5	3/4-16UNF-2B	3/8 Gas (BSPP)
		Outlet	13 [0.512]	30 [1.181]	M6	12 [0.462]	26 [1.024]	M5	M18x1.5	9/16-18UNF-2B	3/8 Gas (BSPP)
012	Inlet	13 [0.512]	30 [1.181]	M6	12 [0.462]	26 [1.024]	M5	M18x1.5	3/4-16UNF-2B	3/8 Gas (BSPP)	
	Outlet	13 [0.512]	30 [1.181]	M6	12 [0.462]	26 [1.024]	M5	M18x1.5	9/16-18UNF-2B	3/8 Gas (BSPP)	

Group 1 Gear Pumps Technical Information Product Options

Integral relief valve

SNP11N

Turolia OCG offers an optional integral relief valve integrated in the rear cover. It is drained internally and directs all flow from the pump outlet to the inlet when the outlet pressure reaches the valve setting.

⚠ Caution

When the relief valve is operating in bypass condition, rapid heat generation occurs. If this bypass condition continues, the pump prematurely fails. The reason for this is that it is a rule, not an exception.

Valve performance graph

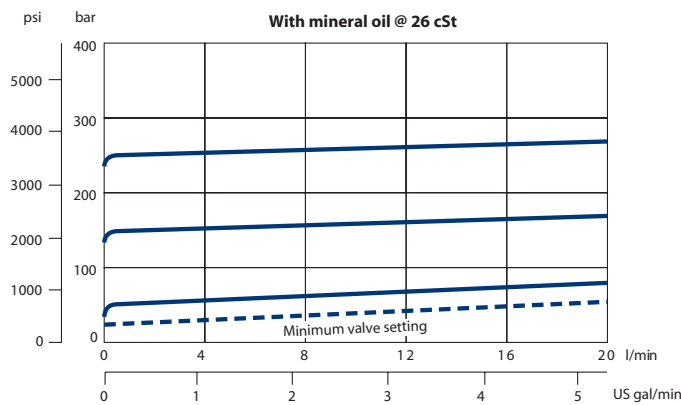

Integral relief valve covers SNP11N

Dimensions

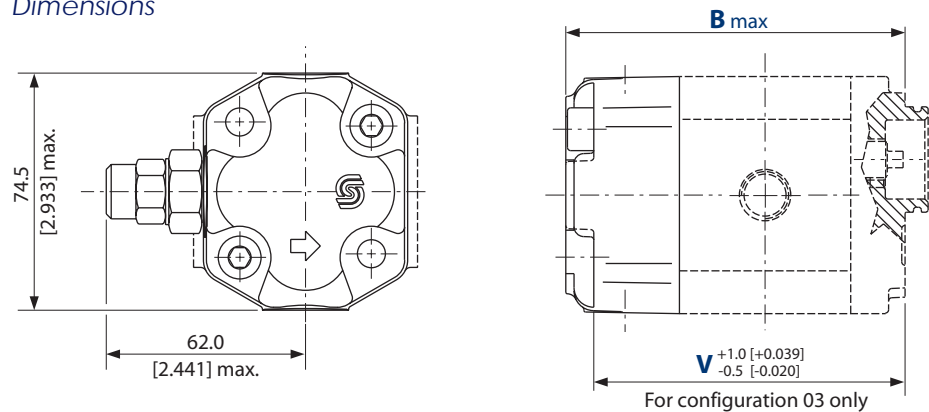

For configuration **06** (SAE A-A) dimension **B** and **V** have to be increased 4.5 mm [0.177 in].

Integral relief valve and covers dimensions

Type (displacement)	1,2	1,7	2,2	2,6	3,2	3,8	4,3	6,0	7,8	010	012	
Dimensions mm [in]	B	95.5 [3.760]	97 [3.819]	99 [3.989]	101 [3.976]	103 [4.055]	105 [4.134]	107 [4.213]	113.5 [4.468]	120 [4.724]	129 [5.079]	137 [5.394]
	V	85.0 [3.346]	86.5 [3.406]	88.5 [3.484]	90.5 [3.563]	92.5 [3.642]	94.5 [3.720]	96.5 [3.799]	103.0 [4.055]	109.5 [4.311]	118.5 [4.665]	126.5 [4.980]

Variant codes for ordering integral relief valves

These tables detail the various codes for ordering integral relief valves:



Code	Pump speed for RV setting min ⁻¹ (rpm)
A	Not defined
C	500
E	1000
F	1250
G	1500
K	2000
I	2250
L	2500
M	2800
N	3000
O	3250

Code	Pressure setting bar [psi]
A	No setting
B	No valve
C	18 [261]
D	25 [363]
E	30 [435]
F	35 [508]
G	40 [580]
K	50 [725]
L	60 [870]
M	70 [1015]
N	80 [1160]
O	90 [1305]
P	100 [1450]
Q	110 [1595]
R	120 [1740]
S	130 [1885]
T	140 [2030]
U	160 [2320]
V	170 [2465]
W	180 [2611]
X	210 [3045]
Y	240 [3480]
Z	250 [3626]

Integral relief valve schematic

Valve schematic

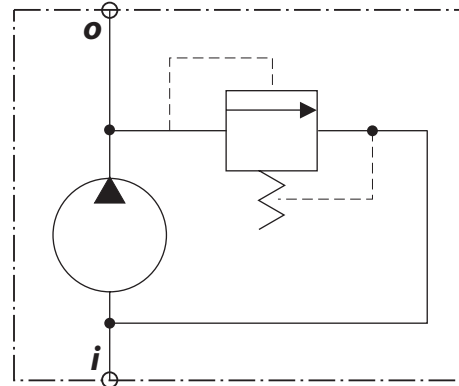

i = inlet
o = outlet

SNP1NN – 01BA and 01DA

This drawing shows the standard porting for 01BA and 01DA.
Available in Series SNP1NN only.

mm
[in]

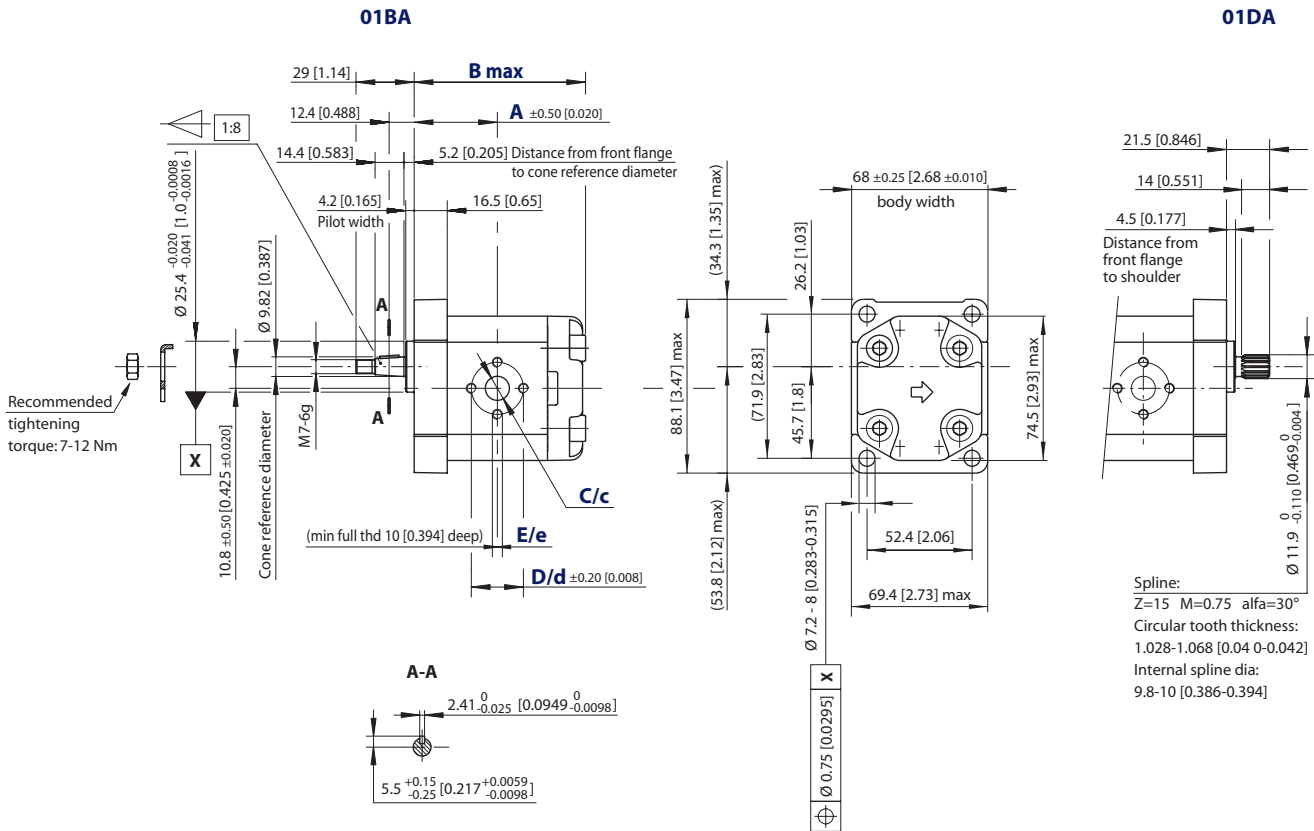

SNP1NN – 01BA and 01DA dimensions

Frame size		1,2	1,7	2,2	2,6	3,2	3,8	4,3	6,0	7,8
Dimension	A	37.75 [1.486]	38.5 [1.516]	39.5 [1.555]	40.5 [1.634]	41.5 [1.634]	42.5 [1.673]	43.5 [1.713]	46.75 [1.841]	50.0 [1.969]
	B	79.5 [3.130]	81.0 [3.189]	83.0 [3.268]	85.0 [3.346]	87.0 [3.425]	89.0 [3.504]	91.0 [3.583]	97.5 [3.839]	104.0 [4.094]
Inlet/Outlet	C/c	12 [0.472]								
	D/d	26 [1.024]								
	E/e	M5								

Model code examples and maximum shaft torque

Flange/drive gear	Model code example	Maximum shaft torque
01BA	SNP1NN/3,8RN01BAP1C2C2NNNNN/NNNNN	25 N·m [221 lb·in]
01DA	SNP1NN/6,0LN01DAP1C2C2NNNNN/NNNNN	35 N·m [310 lb·in]

For further details on ordering, see *Model Code*, pages 6-7.

SKP1NN – 02BB and 02FA

This drawing shows the standard porting for 02BB and 02FA.
Available in Series SKP1NN only.

mm
[in]

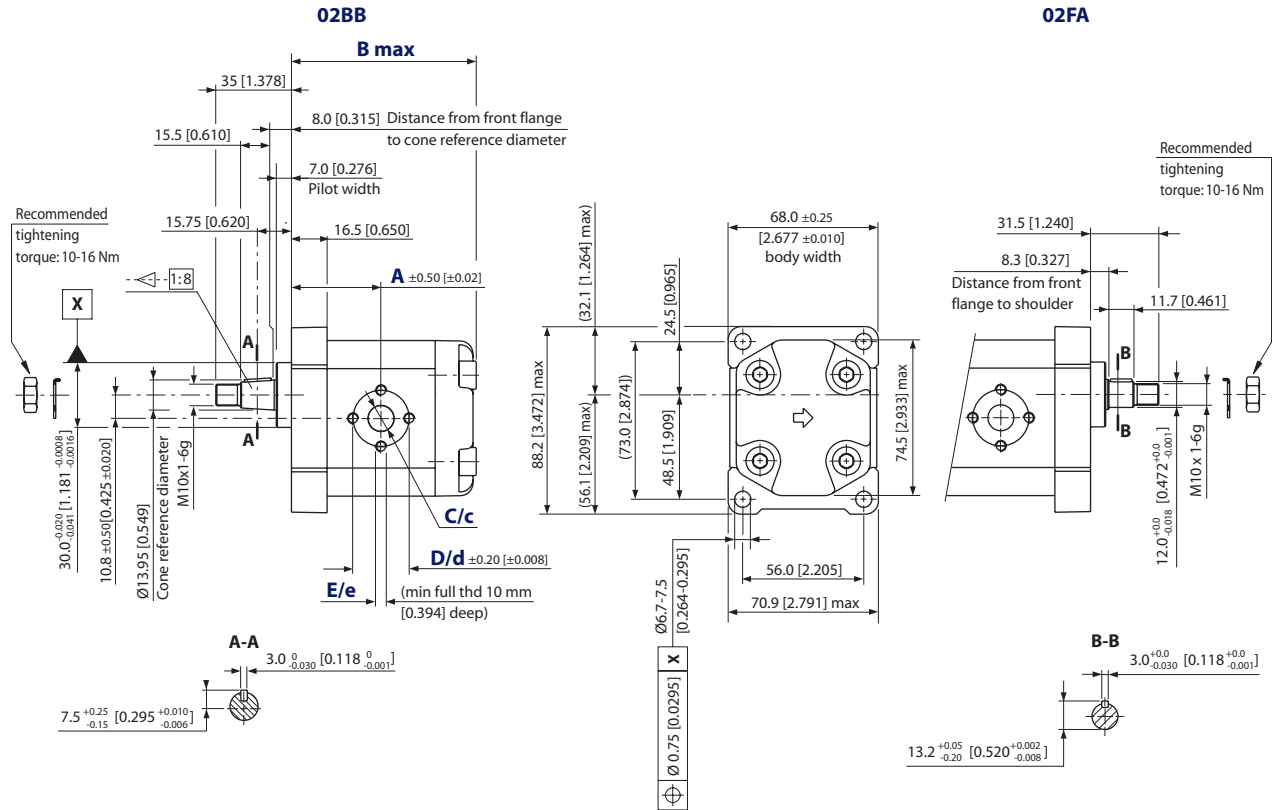

SKP1NN – 02BB and 02FA dimensions

Frame size		1,2	1,7	2,2	2,6	3,2	3,8	4,3	6,0	7,8	010	012
Dimension	A	37.75 [1.486]	38.5 [1.516]	39.5 [1.555]	40.5 [1.634]	41.5 [1.634]	42.5 [1.673]	43.5 [1.713]	46.75 [1.841]	50.0 [1.969]	54.5 [2.146]	58.5 [2.303]
	B	79.5 [3.130]	81.0 [3.189]	83.0 [3.268]	85.0 [3.346]	87.0 [3.425]	89.0 [3.504]	91.0 [3.583]	97.5 [3.839]	104.0 [4.094]	113.0 [4.449]	121.0 [4.764]
Inlet/Outlet	C/c	12 [0.472]										
	D/d	26 [1.024]										
	E/e	M5										

Model code examples and maximum shaft torque

Flange/drive gear	Model code example	Maximum shaft torque
02BB	SKP1NN/6,ORN02BBP1C2C2NNNN/NNNNN	50 N•m [442 lb•in]
02FA	SKP1NN/2,2LN02FAP1C2C2NNNN/NNNNN	24 N•m [212 lb•in]

For further details on ordering, see *Model Code*, pages 6-7.

SKP1NN – 06GA and 06SA

This drawing shows the standard porting for 06GA and 06SA.
Available in Series SKP1NN only.

mm
[in]

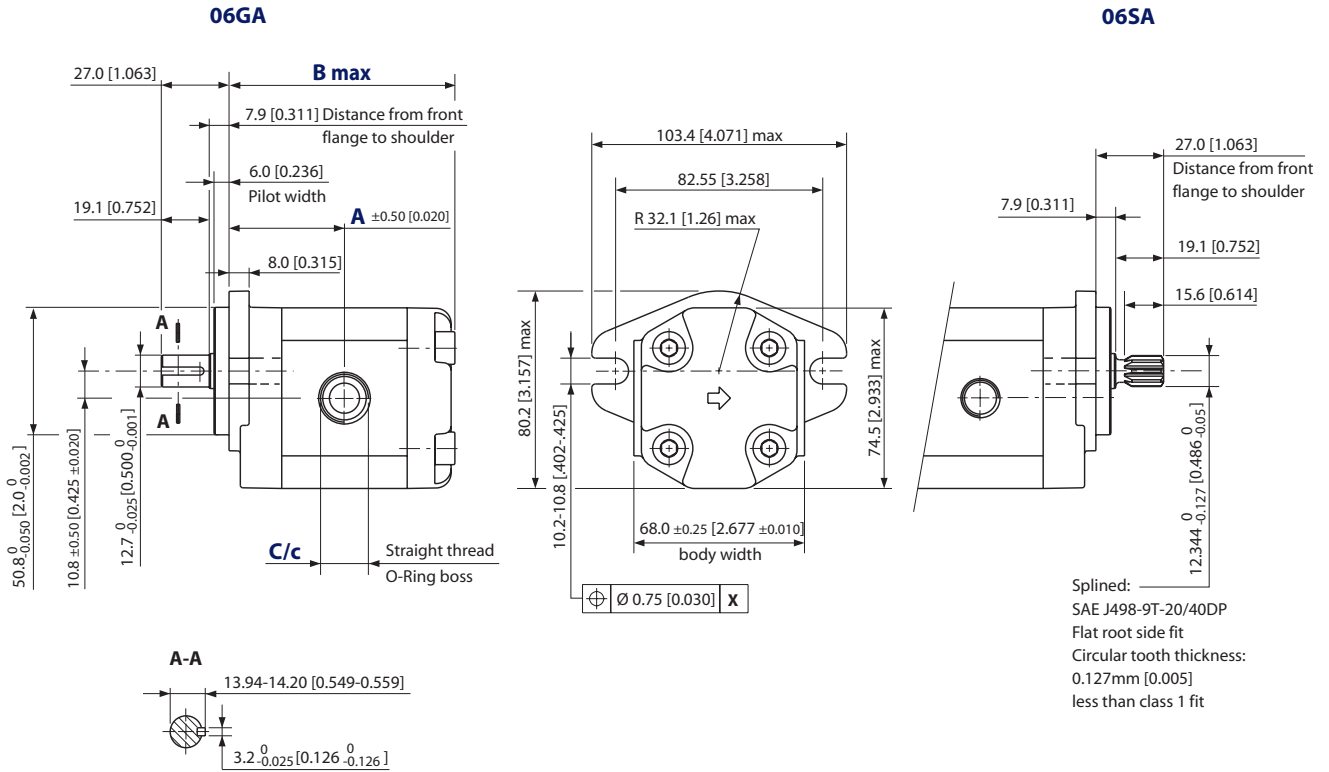

SKP1NN – 06GA and 06SA dimensions

Frame size		1,2	1,7	2,2	2,6	3,2	3,8	4,3	6,0	7,8	010	012
Dimension	A	42.25 [1.663]	43 [1.693]	44 [1.732]	45.0 [1.772]	46.0 [1.811]	47 [1.850]	48 [1.890]	51.25 [2.018]	54.5 [2.146]	59 [2.323]	63.5 [2.50]
	B	84 [3.307]	85.5 [3.366]	87.5 [3.445]	89.5 [3.524]	91.5 [3.602]	93.5 [3.681]	95.5 [3.760]	102 [4.016]	108.5 [4.272]	117.5 [4.626]	125.5 [4.941]
Inlet	C	3/4–16UNF–2B, THD 14.3 [0.563] deep										
Outlet	c	9/16–18UNF–2B, THD 12.7 [0.500] deep										

Model code examples and maximum shaft torque

Flange/drive gear	Model code example	Maximum shaft torque
06GA	SKP1NN/3,2RN06GAP1E4E3NNNN/NNNNN	32 N•m [283 lb•in]
06SA	SKP1NN/012LN06SAP1E4E3NNNN/NNNNN	34 N•m [301 lb•in]

For further details on ordering, see *Model Code*, pages 6-7.

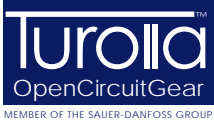

Our Products

Aluminum Gear Pumps

Aluminum Gear Motors

Cast Iron Gear Pumps

Cast Iron Gear Motors

Fan Drive Gear Motors Aluminum

Fan Drive Gear Motors Cast Iron

Turolla OpenCircuitGear™

Turolla OCG, with more than 60 years of experience in designing and manufacturing gear pumps, gear motors and fan drive motors of superior quality, is the ideal partner ensuring robustness and reliability to your work functions.

We are fast and responsive - the first to specify a customer product, the most experienced in providing technical knowledge and support for fan drive solutions.

We offer a lean value chain to our partners and customers and the shortest lead time in the market.

Turolla OCG is member of the Sauer-Danfoss Group.

Local address:

Turolla OpenCircuitGear

Via Villanova 28
40050 Villanova di Castenaso
Bologna, Italy
Phone: +39 051 6054411
Fax: +39 051 6053033

Turolla OpenCircuitGear

Kuku inova 2148-84
01701 Považská Bystrica, Slovakia
Phone: +421 424 301 544
Fax: +421 424 301 626

Turolla OpenCircuitGear

2800 East 13th Street
Ames, IA 50010
USA
Phone: +1 515 239 6000
Fax: +1 515 239 6618